

MICHIGAN ELECTRIC UTILITY

Generator Interconnection Requirements

***Category 4
Projects with
Aggregate Generator Output
Greater Than 550 kW, but Less Than or
Equal to 2 MW***

September 1, 2009

INTRODUCTION

Category 4

This Generator Interconnection Procedure document outlines the process & requirements used to install or modify generation projects with aggregate generator output capacity ratings greater than 550 kW, but less than or equal to 2 MW designed to operate in parallel with the Consumers Energy electric system. Technical requirements (data, equipment, relaying, telemetry, metering) are defined according to generation type, location of the interconnection, and mode of operation (Flow-back or Non-Flow-back). The process is designed to provide an expeditious interconnection to the Consumers Energy electric system that is both safe and reliable.

This document has been filed with the Michigan Public Service Commission (MPSC) and complies with rules established for the interconnection of parallel generation to the Consumers Energy electric system in the MPSC Order in Case No. U-15787

The term “Project” will be used throughout this document to refer to electric generating equipment and associated facilities that are not owned or operated by Consumers Energy. The term “Project Developer” means a person that owns, operates, or proposes to construct, own, or operate, a Project.

This document does not address other Project concerns such as environmental permitting, local ordinances, or fuel supply. Nor does it address agreements that may be required with Consumers Energy and/or the transmission provider, or state or federal licensing, to market the Project’s energy. An interconnection request does not constitute a request for transmission service.

It may be possible for Consumers Energy to adjust requirements stated herein on a case-by-case basis. The review necessary to support such adjustments, however, may be extensive and may exceed the costs and timeframes established by the MPSC and addressed in these requirements. Therefore, if requested by the Project Developer, adjustments to these requirements will only be considered if the Project Developer agrees in advance to compensate Consumers Energy for the added costs of the necessary additional reviews and to also allow Consumers Energy additional time for the additional reviews.

Consumers Energy may apply for a technical waiver from one or more provisions of these rules and the MPSC may grant a waiver upon a showing of good cause.

TABLE OF CONTENTS

INTERCONNECTION PROCEDURES

Interconnection Process	5
Customer Project Planning Phase.....	5
Application & Queue Assignment	5
Application Review	5
Engineering Review.....	5
Distribution Study.....	6
Customer Install & Parallel Operating Agreement.....	6
Meter Install, Testing, & Inspection.....	6
Operation in Parallel	7
Operational Provisions.....	7
Disconnection	7
Maintenance and Testing	7

TECHNICAL REQUIREMENTS

Major Component Design Requirements	8
Data	8
Isolating Transformer(s).....	8
Isolation Device	9
Interconnection Lines.....	9
Termination Structure	10
Relaying Design Requirements	10
Protective Relaying General Considerations	10
Momentary Paralleling.....	11
Instrument Transformer Requirements.....	11
Direct Transfer Trip (DTT)	11
Reverse Power Relaying for Non Flow-back.....	12
Automatic Reclosing.....	12
Single-Phase Sectionalizing	12
Synchronous Projects.....	13
Induction Projects	14
Inverter Projects.....	15
Relay Setting Criteria.....	16
Maintenance and Testing	17
Installation Approval	18
Telemetry and Disturbance Monitoring Requirements	18
Miscellaneous Operational Requirements	20
Operating in Parallel	20
Reactive Power Control.....	22
Standby Power	22
System Stability and Site Limitations.....	23

Revenue Metering Requirements..... 23
Communication Circuits..... 24

Appendix A – Interconnection Process Flow Diagram

Appendix B – Interconnection Fees and Timelines

Appendix C – Procedure Definitions

Appendix D – Interconnection Application

Appendix E – Engineering Review and Distribution Study Agreements

Appendix F – Interconnection and Parallel Operating Agreement

Appendix G – Contact List

INTERCONNECTION PROCEDURES

Interconnection Process

Customer Project Planning Phase

A Project Developer may contact Consumers Energy before or during the application process regarding the project. Consumers Energy can be reached by phone, e-mail, or by the external website to access information, forms, rates, and agreements. Consumers Energy will provide up to 2 hours of technical consultation at no additional cost to the applicant. Consultation may be limited to providing information concerning the utility system operating characteristics and location of system components.

An interconnection process flow diagram can be found in Appendix A.

Interconnection fees and timelines can be found in **Appendix B**. Procedure definitions can be found in **Appendix C**.

Application & Queue Assignment

The Project Developer must first submit an Interconnection Application (**Appendix D**) to Consumers Energy. A separate application is required for each Project, or Project site. Consumers Energy will notify the Project Developer within 10 working days of receipt of an Interconnection Application. If any portion of the Interconnection Application, data submittal (site plan and one-line diagrams), or filing fee is incomplete and/or missing; Consumers Energy will return the application, data, and filing fee to the Project developer with explanations. The Project Developer will need to resubmit the application with all the missing items. Once Consumers Energy has accepted the application, a queue number will be assigned to the Project, and Consumers Energy will notify the Project Developer that the application is complete.

Application Review

Consumers Energy will review the complete Interconnection Application to determine if an engineering review is required. If an engineering review is required, Consumers Energy will notify the Project Developer within 10 working days, and provide the Project Developer with an Engineering Review Agreement (**Appendix E**). A review fee will be required (**Appendix B**). The Project Developer shall provide any changes or updates to the application before the engineering review begins. If an engineering review is not required, the project will advance to the Customer Install & Parallel Operating Agreement phase of the process. Consumers Energy may request additional data be submitted as necessary during the review phase to clarify the operation of the Project.

Engineering Review

Upon receiving an executed Engineering Review Agreement and the review fee; Consumers Energy will study the project to determine the suitability of the interconnection equipment including safety and reliability complications arising from equipment saturation, multiple

technologies, and proximity to synchronous motor loads. Consumers Energy will provide in writing the results of the engineering review within 25 working days. The engineering review will include major components affected, potential system upgrades, and a non-binding estimate (as practically possible) for interconnection. If the engineering review indicates that a distribution study is necessary, Consumers Energy will provide the Project Developer with a Distribution Study Agreement (**Appendix E**), and a study fee will be required (**Appendix B**). If an engineering review determines that a distribution study is not required, the project will advance to the Customer Install & Parallel Operating Agreement phase of the process.

Distribution Study

Upon receiving an executed Distribution Study Agreement and study fee; Consumers Energy will study the project to determine if electric distribution system upgrade(s) are needed to accommodate the proposed project, and determine the cost of electric system upgrade(s) if required. Consumers Energy will provide in writing the results of the distribution study within 45 working days. The distribution study will include the estimated completion timeframe and cost estimate for the electric system upgrade(s). If the distribution study determines that electric system upgrades are not required, the project will advance to the Customer Install & Parallel Operating Agreement phase of the process.

Customer Install & Parallel Operating Agreement

The Project Developer shall notify Consumers Energy when the generator installation and any required local code inspection and approval is complete. The Parallel Operating Agreement will cover matters customarily addressed in such agreements in accordance with Good Utility Practice, including and without limitation, construction of facilities, system operation, defaults and remedies, and liability. The Project Developer shall complete, sign and return the Interconnection and Parallel Operating Agreement (**Appendix F**), Contact List (**Appendix G**), a Facilities Agreement if electric system upgrades are required, and any required payment for system upgrades to Consumers Energy. Any delay in the Project Developer's execution of the Interconnection and Parallel Operating Agreement, Contact List, Facilities Agreement, or payment will not count toward the estimated completion timeframe.

Meter Install, Testing, & Inspection

Upon receipt of the local code inspection approval, completion of the Consumers Energy electric system upgrades and executed Parallel Operating Agreement; Consumers Energy will schedule the meter install, testing, and inspection.

Prior to final approval for Parallel Operation, Consumers Energy's specified relay calibration settings shall be applied and a commissioning test must be performed on the Project relaying and control equipment that involves the protection of Consumers Energy electric system. The commissioning test must be witnessed by Consumers Energy, and can be performed by Consumers Energy at the Project Developer's request. Within 5 working days from receipt of the completed commissioning test report, Consumers Energy will notify the Project Developer of its approval, or disapproval, of the interconnection. If Consumers Energy does not approve the interconnection, Consumers Energy will notify the Project Developer of the necessary corrective actions required for approval. The Project Developer, after taking corrective action, may request Consumers Energy to reconsider the interconnection request.

Operation in Parallel

Upon Consumers Energy approval of the interconnection, Consumers Energy will install required metering, provide a written statement of final approval, and a fully executed Parallel Operating Agreement authorizing parallel operation.

Operational Provisions

Disconnection

Consumers Energy may refuse to connect, or may disconnect, a project from the electric system if any of the following conditions apply:

- a. Lack of fully executed Interconnection and Parallel Operating Agreement
- b. Termination of interconnection by mutual agreement
- c. Noncompliance with technical or contractual requirements in the Interconnection and Parallel Operating Agreement, after notice is provided to the Project Developer of the technical or contractual deficiency.
- d. Electric distribution system emergency
- e. Routine maintenance, repairs, and modifications, but only for a reasonable length of time necessary to perform the required work and upon reasonable notice.

Maintenance and Testing

Routine and maintenance checks of the relaying and control equipment must be conducted in accordance with provided written test procedures which are required by IEEE Std. 1547, and test reports of such testing shall be maintained by the applicant and made available for Utility inspection upon request. [NOTE – IEEE 1547 requires that testing be conducted in accordance with written test procedures, and the nationally recognized testing laboratory providing certification will require that such test procedures be available before certification of the equipment.]

TECHNICAL REQUIREMENTS

The following discussion details the technical requirements for interconnection of Category 4 Projects greater than 550 kW, but less than or equal to 2 MW of generation. Many of these requirements will vary based on the capacity rating of the Project, generation type, and mode of operation (Flow-back or Non-Flow-back). A few of the requirements will vary based on location of the interconnection (isolated load and available fault current).

Certain major component, relaying, telemetry, and operational requirements must be met to provide compatibility between the Project equipment and the Consumers Energy electric system, and to assure that the safety and reliability of the electric system is not degraded by the interconnection. Consumers Energy reserves the right to evaluate and apply newly developed protection and/or operation schemes at its discretion. All protective schemes and functions are evaluated for compliance to IEEE std. 1547. In addition, Consumers Energy reserves the right to evaluate Projects on an ongoing basis as system conditions change, such as circuit loading, additional generation placed online, etc.

Upgraded revenue metering may be required for the Project.

Major Component Design Requirements

The data requested for all major equipment and relaying proposed by the Project Developer, must be submitted as part of the initial generator interconnection application for review and approval by Consumers Energy (Appendix D). Consumers Energy may request additional data be submitted as necessary during the interconnection process to clarify the operation of the Project facilities.

Once installed, the interconnection equipment must be reviewed and approved by Consumers Energy prior to being connected to the Consumers Energy electric system, and before parallel operation is allowed.

Data

The data that Consumers Energy requires to evaluate the proposed interconnection is documented on the generator interconnection application (Appendix D).

A site plan, one-line diagram(s), and interconnection protection system details of the Project are required as part of the application data (Appendix D). [The one-line diagram\(s\) must be signed and sealed by a state of Michigan licensed professional engineer, or by a state of Michigan licensed electrical contractor with the electrical contractor's license number noted on the diagram.](#) The generator manufacturer data package should also be supplied.

Isolating Transformer(s)

If an isolating transformer is required, the transformer must comply with the current ANSI Standard C57.12.

The transformer must have voltage taps on the high and/or low voltage windings sufficient to assure satisfactory generator operation over the range of voltage variation expected on the

Consumers Energy electric system. The Project Developer also needs to assure sufficient voltage regulation at its facility to maintain an acceptable voltage level for its equipment during such periods when its Project is off-line. This may involve the provision of voltage regulation or a separate transformer between Consumers Energy and the Project station power bus.

The type of generation and electrical location of the interconnection will determine the isolating transformer connections. Allowable connections are detailed under the specific Project type. Note: Some Utilities do not allow an isolation transformer to be connected to a grounded Utility system with an ungrounded secondary (Utility side) winding configuration, regardless of the Project type. Therefore, the Project Developer is encouraged to consult with Consumers Energy prior to submitting an application.

The proper selection and specification of transformer impedance is important relative to enabling the proposed Project to meet Consumers Energy's reactive power requirements (see "Reactive Power Control").

Isolation Device

An isolation device is required and should be placed at the Point of Common Coupling (PCC). It can be a circuit breaker, circuit switcher, pole top switch, load-break disconnect, etc., depending on the electrical system configuration. The following are required of the isolation device:

- Must be approved for use on the Consumers Energy electric system.
- Must comply with current relevant ANSI and/or IEEE Standards.
- Must have load break capability, unless used in series with a three-phase interrupting device.
- Must be rated for the application.
- If used as part of a protective relaying scheme, it must have adequate interrupting capability. Consumers Energy will provide maximum short circuit currents and X/R ratios available at the PCC upon request.
- Must be operable and accessible by Consumers Energy at all times (24 hours a day, 7 days a week).
- Consumers Energy will determine if the isolation device will be used as a protective tagging point. If the determination is so made, the device must have visible open break provisions for padlocking in the open position, and it must be gang operated. If the device has automatic operation, the controls must be located remote from the device.

Interconnection Lines

The physically closest available system voltage, as well as equipment and operational constraints influence the chosen point of interconnection. Consumers Energy has the ultimate authority to determine the acceptability of a particular PCC.

Any new line construction to connect the Project to the Consumers Energy's electric system will be undertaken by Consumers Energy at the Project Developer's expense. Consumers Energy

may require the new line construction to be terminated on a termination structure provided by the Project Developer.

Termination Structure

The Project Developer is responsible for ensuring that structural material strengths are adequate for all requirements, incorporating appropriate safety factors. Upon written request, Consumers Energy will provide line tension information for maximum dead-end tensions under heavy icing conditions. The structure must be designed for this maximum line tension along with an adequate margin of safety.

Electrical clearances shall comply with requirements of the National Electrical Safety Code and Michigan Public Service Commission Standard 16-79.

The installation of disconnect switches, bus support insulators, and other equipment shall comply with accepted industry practices.

Surge arresters shall be selected to coordinate with the BIL rating of major equipment components and shall comply with recommendations set forth in the current ANSI Standard C62.2.

Relaying Design Requirements

The interconnection relaying design requirements are intended to assure protection of the Consumers Energy electric system. Any additional relaying which may be necessary to protect equipment at the Project is solely the responsibility of the Project Developer to determine, design, and apply.

The relaying requirements will vary with the capacity rating of the Project, the type of generation being used, and the mode of operation (Flow-back or Non Flow-back).

All relaying proposed by the Project Developer to satisfy these requirements must be submitted for review and approved by Consumers Energy.

Protective Relaying General Considerations

Utility grade relays are required. See "Approved Relay Types" in the Generator Interconnection Supplement.

All relays must be equipped with targets or other visible indicators to indicate that the relay has operated.

If the protective system uses AC power as the control voltage, it must be designed to disconnect the generation from the Consumers Energy electric system if the AC control power is lost. Consumers Energy will work with the Project Developer regarding the system design for this requirement.

The relay system must be designed such that the Project Developer is prevented from energizing the Consumers Energy electric system if that system is de-energized.

Momentary Paralleling

For situations where the Project will only be operated in parallel with Consumers Energy electric system for a short duration (100 milliseconds or less), as in a make-before-break automatic transfer scheme, no additional relaying is required. Such momentary paralleling requires a modern integrated Automatic Transfer Switch (ATS) system, which is incapable of paralleling the Project with the Consumers Energy electric system. The ATS must be tested and verified for proper operation at least every 2 years. Consumers Energy may be present during this testing.

Instrument Transformer Requirements

All relaying must be connected into instrument transformers.

All current connections shall be connected into current transformers (CTs). All CTs shall be rated to provide no more than 5 amperes secondary current for all normal load conditions, and must be designed for relaying use, with an “accuracy class” of at least C50. Current transformers with an accuracy class designation such as T50 are NOT acceptable. For three-phase systems, all three phases must be equipped with CTs.

All potential connections must be connected into voltage transformers (VTs). For single-phase connections, the VTs shall be provided such that the secondary voltage does not exceed 120 volts for normal operations. For three-phase connections, the VTs shall be provided such that the line-to-line voltage does not exceed 120 volts for normal operation, and both the primary and secondary of the VTs shall be connected for grounded-wye connections.

Direct Transfer Trip (DTT)

Direct Transfer Trip is generally not required for Induction or Inverter-Type Projects. Direct Transfer Trip is generally not required for Synchronous Projects that will operate in the Non Flow-back Mode since a more economic reverse power relay scheme can usually meet the requirements. For Flow-back Projects, the need for DTT is determined based on the location of the PCC. Consumers Energy requires DTT when the total generation within a protective zone is greater than 33% of the minimum Utility load that could be isolated along with the generation. This prevents sustained isolated operation of the generation for conditions where Project protective relaying may not otherwise operate (see “Isolated Operation” in the Generator Interconnection Supplement).

Direct transfer trip adds to the cost and complexity of an interconnection. A DTT transmitter is required for each Utility protective device whose operation could result in sustained isolated operation of the Project. An associated DTT receiver at the Project is required for each DTT transmitter. A Data Circuit is required between each transmitter and receiver. Telemetry is required to monitor status of the DTT communication, even if telemetry would not otherwise have been required.

At the Project Developer’s expense, Consumers Energy will provide the receiver(s) that the Project Developer must install, and Consumers Energy will install the transmitter(s) at the appropriate Utility protective devices.

Reverse Power Relaying for Non Flow-back

If Flow-back Mode is not utilized, reverse power protection must be provided. The reverse power relaying will detect power flow from the Project into the Consumers Energy system, and operation of the reverse power relaying will separate the Project from the Consumers Energy system.

Automatic Reclosing

Consumers Energy employs automatic multiple-shot reclosing on most of the circuit breakers and circuit reclosers to increase the reliability of service to its customers. Automatic single-phase overhead reclosers are regularly installed on distribution circuits to isolate faulted segments of these circuits.

The Project Developer is advised to consider the effects of Automatic Reclosing (both single-phase and three-phase) to assure that the Project's internal equipment will not be damaged. In addition to the risk of damage to the Project, an out-of-phase reclosing operation may also present a hazard to Consumers Energy's electric system equipment since this equipment may not be rated or built to withstand this type of reclosing.

To prevent out-of-phase reclosing, circuit breakers can be modified with voltage check relays. These relays block reclosing until the parallel generation is separated and the line is "de-energized." Hydraulic single-phase overhead reclosers cannot be modified with voltage check relays; therefore, these devices will have to be either replaced with three-phase overhead reclosers, which can be voltage controlled, or relocated beyond the Project location – depending upon the sectionalizing and protection requirements of the distribution circuit.

If the Project can be connected to more than one circuit, these revisions may be required on the alternate circuit(s) as well.

Consumers Energy will determine relaying and control equipment that needs to be installed to protect its own equipment from out-of-phase reclosing. Installation of this protection will be undertaken by Consumers Energy at the Project Developer's expense. Consumers Energy shall not be liable to the customer with respect to damage(s) to the Project arising as a result of Automatic Reclosing.

Single-Phase Sectionalizing

Consumers Energy also installs single-phase fuses and/or reclosers on its distribution circuits to increase the reliability of service to its customers. Three-phase generator installations may require replacement of fuses and/or single-phase reclosers with three-phase circuit breakers or circuit reclosers at the Project Developer's expense.

Synchronous Projects

Under/overfrequency relaying and under/overvoltage relaying are required. Each Project must also be equipped with voltage-controlled overcurrent relays to detect faults on the Consumers Energy electric system. The under/overvoltage relaying must be either a three-phase relay or three single-phase relays, and three-phase voltage controlled overcurrent relaying must be provided. In order to minimize damage to both Project equipment and to the Consumers Energy electric system equipment for loss-of-synchronism (also called out-of-step), and to minimize disruptions to other Consumers Energy customers in the area, out-of-step relaying may also be required. Consumers Energy has evaluated and approved a relay for this purpose, which would usually be installed at the same location as the metering, and would isolate the Project from the Consumers Energy electric system.

If the Project is connected to an ungrounded distribution system, the secondary winding (Utility side) of the isolation transformer must be connected delta.

If the Project is connected to a grounded distribution system, the Project Developer has a choice of the following transformer connections:

1. A grounded-wye - grounded-wye transformer connection is acceptable only if the Project's single line-to-ground fault current contribution is less than the Project's three-phase fault current contribution at the PCC.
2. The isolation transformer may be connected for a delta secondary (Utility side) connection with any primary (Project side) connection, or
3. Ungrounded-wye secondary connection with a delta primary connection.

If the Project is connected to a grounded distribution system via one of the isolation transformer connections specified above, ground fault detection for utility faults may be required at the discretion of Consumers Energy, and will consist of a (59N) ground overvoltage relay or (51N) overcurrent relay. The specific application of this relay will depend on the connection of the isolation transformer:

1. If a delta secondary/grounded-wye primary connection is used, the (59N) relay will be connected into the secondary of a set of three-phase VTs, which will be connected grounded-wye primary, with the secondary connected delta with one corner of the delta left open. The (59N) relay will be connected across this open-corner.
2. If an ungrounded-wye secondary/delta primary connection is used, the (59N) relay will be connected into the secondary of a single VT that will be connected from the ungrounded-wye neutral of the isolation transformer to ground.
3. If a grounded-wye - grounded-wye transformer connection is used, a time overcurrent relay must be connected into a CT located on the Utility side isolation transformer neutral connection.

In some instances, additional isolation transformer connection options may be available and will be determined by Consumers Energy for the specific system location. The potential connection alternatives will include all alternatives listed above for application on a grounded distribution system, but will add a possible connection of grounded-wye (Utility side), delta (Project side). In the case of this additional isolation transformer connection, utility system ground fault detection will take the form of a time overcurrent relay connected into a current transformer located in the Utility-side transformer neutral. This time overcurrent relay must have a very-inverse time characteristic.

For a sample One-Line Diagram of this type of facility including the various methods of (59N) application, see Appendix D.

Induction Projects

Three-phase under/overvoltage relays and three-phase under/overfrequency relays must be provided. Utility-grade relays are required.

If the Project is connected to an ungrounded distribution system, the secondary winding (Utility side) of the isolation transformer must be connected delta.

If the Project is connected to a grounded distribution system, the developer has a choice of the following transformer connections:

1. The isolation transformer may be connected for a delta secondary (Utility side) connection with any primary (Project side) connection, or
2. The isolation transformer may be connected for an ungrounded-wye secondary (Utility side) connection with a delta primary (Project side) connection.
3. The isolation transformer may be connected for a grounded-wye - grounded-wye connection.

If the Project is connected to a grounded distribution system via one of the isolation transformer connections specified above, ground fault detection for utility faults must be provided. The specific application of this relay will depend on the connection of the isolation transformer:

1. If a delta secondary/grounded-wye primary connection is used, a (59N) ground overvoltage relay will be connected into the secondary of a set of three-phase VTs, which will be connected grounded-wye primary, with the secondary connected delta with one corner of the delta left open. The (59N) relay will be connected across this open-corner.
2. If an ungrounded-wye secondary/delta primary connection is used, a (59N) ground overvoltage relay will be connected into the secondary of a single VT that will be connected from the ungrounded-wye neutral of the isolation transformer to ground.
3. If a grounded-wye - grounded-wye connection is used, a time overcurrent relay must be connected into a CT located on the Utility side isolation transformer neutral connection.

Protection must be provided for internal faults in the isolating transformer. In cases where it can be shown that self excitation of the induction generator cannot occur when isolated from the Consumers Energy, Consumers Energy may waive the requirement that the Project Developer provide protection for utility system ground faults. In all cases, ground fault detection for utility faults may be required at the discretion of Consumers Energy.

For a sample One-Line Diagram of this type of facility, see Appendix D.

Inverter Projects

Under/overfrequency relaying and under/overvoltage relaying are required. The under/overvoltage relaying must be either a three-phase relay or three single-phase relays.

The isolation transformer (without generation on-line) must be incapable of producing ground fault current to the Consumers Energy electric system; any connection except delta primary (Project side), grounded-wye secondary (Utility side) is acceptable. The isolation transformer must be protected for internal faults; fuses are acceptable.

If the inverter has passed a certified anti-island test, Consumers Energy may waive the requirement that the generator Project Developer provide protection for the utility system ground faults. In all cases, ground fault detection for utility faults may be required at the discretion of Consumers Energy. If required, type and methodology will be the same as Synchronous Projects listed above.

For a sample One-Line Diagram of this type of facility, see Appendix D.

Relay Setting Criteria

The relay settings as detailed in this section will apply in the vast majority of applications. Consumers Energy will issue relay settings for each individual Project Developer that will address the settings for these protective functions. All voltages will be adjusted for the specific VT ratio, and all currents will be adjusted for the specific CT ratio.

Undervoltage Relays

The undervoltage relays will normally be set to trip at 88% of the nominal primary voltage at the relay location, and must reset from a trip condition if the voltage increases to 90% of the nominal primary voltage at the relay location. In order to accommodate variations in this criteria, the trip point of the relays shall be adjustable over a range of 70% of the nominal voltage to 90% of the nominal voltage. The trip time shall not exceed 1.0 seconds at 90% of the relay setting.

Overvoltage Relays

Two steps of overvoltage relaying are required. For the first overvoltage set point, the overvoltage relays will normally be set to trip at 107% of the nominal primary voltage at the relay location, and must reset from a trip condition if the voltage decreases to 105% of the nominal primary voltage at the relay location. In order to accommodate variations in this criteria, the trip point of the relays shall be adjustable over a range of 105% of the nominal voltage to 120% of the nominal voltage. The trip time shall not exceed 1.0 seconds at 110% of the relay setting.

For the second overvoltage set point, the overvoltage relays will normally be set to trip at 120% of the nominal primary voltage at the relay location, and must reset from a trip condition if the voltage decreases to 118% of the nominal primary voltage at the relay location. In order to accommodate variations in this criteria, the trip point of the relays shall be adjustable over a range of 115% of the nominal voltage to 140% of the nominal voltage. The trip time shall be instantaneous (relay operating time not to exceed 0.02 seconds at 110% of the trip setting).

Underfrequency Relays

The Underfrequency relay will normally be set for a trip point of 58.5 Hz, and must trip within 0.2 seconds. Relays with an inverse time characteristic (where the trip time changes with respect to the applied frequency) are not acceptable. These relays must respond reliably for applied source voltages as low as 70% of the nominal voltage.

Overfrequency Relays

The overfrequency relay will normally be set for a trip point of 60.5 Hz, and must trip within 0.2 seconds. Relays with an inverse time characteristic are not acceptable. These relays must respond reliably for applied source voltages as low as 70% of the nominal voltage.

51V Relays – Voltage Controlled Overcurrent Relays

For synchronous Project applications, the (51V) relays must be set to detect any phase faults that may occur between the Project and the nearest three-phase fault clearing device on the Consumers Energy system. Since these faults may take up to 1-second to detect and isolate, the appropriate saturated direct-axis reactance of the Project will be used depending on its time constants. The settings of this device will consider the relay manufacturer's recommended

practice for the type of Project and prime mover (mechanical energy source), and will be determined by Consumers Energy for the specific system application.

59N Relay – Ground Fault Detection

This relay will be applied to detect ground faults on the Consumers Energy system when the Project is connected to a grounded Utility system via an ungrounded transformer winding. This relay will be set for a 10% shift in the apparent power system neutral. For an ungrounded-wye transformer winding with a single 120 V secondary VT, the setting will usually be 12 Volts. For a delta transformer winding with broken delta 120 V secondary VTs, the setting will usually be 20 Volts. The time delay will normally be 1 second.

51N Relay – Ground Fault Detection

This relay will be applied to detect ground faults on the Consumers Energy system when the Project is connected to a grounded Utility system via a grounded-wye transformer winding, and will be connected into a CT in the transformer neutral connection. This relay will be set to detect faults on the directly connected Utility system, and the timing will be set to comply with Utility practice for overcurrent relay coordination. The CT ratio and specific relay setting will be determined via a fault study performed by Consumers Energy.

32 Relay – Reverse Power

The reverse power relay must be selected such that it can detect a power flow into the Consumers Energy system of a small fraction of the overall Project capacity. The relay will normally be set near its minimum (most sensitive) setting, and will trip after a 1 second time delay. The delay will avoid unnecessary tripping for momentary conditions.

Maintenance and Testing

Consumers Energy reserves the right to test the relaying and control equipment that involves protection of the Consumers Energy electric system whenever Consumers Energy determines a reasonable need for such testing exists.

The Project Developer is solely responsible for conducting and documenting proper periodic maintenance on the generating equipment and its associated control, protective equipment, interrupting devices, and main Isolation Device, per manufacturer recommendations.

The Project Developer is responsible for the periodic scheduled maintenance on those relays, interrupting devices, control schemes, and batteries that involve the protection of the Consumers Energy electric system. A periodic maintenance program is to be established to test these relays at least every 2 years. This maintenance testing must be witnessed by Consumers Energy.

Each routine maintenance check of the relaying equipment shall include both an exact calibration check and an actual trip of the circuit breaker or contactor from the device being tested. For each test, a report shall be submitted to Consumers Energy indicating the results of the tests made and the "as found" and "as left" relay calibration values. Visually setting, without verification, a calibration dial or tap is not considered an adequate relay calibration check.

The Project Developer is responsible for maintaining written reports for the above tests for a period of four years. These written reports shall be made available to Consumers Energy upon request.

Installation Approval

The Project Developer must provide Consumers Energy with 10 working days advance written notice of when the Project will be ready for inspection, testing and approval.

Prior to final approval for Parallel Operation, Consumers Energy specified relay calibration settings shall be applied and a commissioning test must be performed on the Project relaying and control equipment that involves the protection of the Consumers Energy electric system. The commissioning test must be witnessed by Consumers Energy, and can be performed by Consumers Energy at the Project Developer's request. Within 5 working days from receipt of the completed commissioning test report, Consumers Energy will notify the Project Developer of its approval or disapproval of the interconnection. If Consumers Energy does not approve the interconnection, Consumers Energy will notify the Project Developer of the necessary corrective actions required for approval. The Project Developer, after taking corrective action, may request Consumers Energy to reconsider the interconnection request.

In the event that revisions are necessary to the Project Developer's submitted design and the Project Developer submits revised design drawings to Consumers Energy, Consumers Energy shall either approve, in writing, the Project Developer's revised design drawings as resubmitted, or return them to the Project Developer with a clear statement as to why they were not approved. Where appropriate, Consumers Energy will indicate required changes on the engineering drawings.

In the event the Project Developer proposes a revision to Consumers Energy's approved relaying and control equipment used to protect the Consumers Energy electric system and submits a description and engineering design drawings of the proposed changes, Consumers Energy shall either approve the Project Developer's amended design drawings or return them to the Project Developer with a clear statement as to why they were not approved. Where appropriate, Consumers Energy will indicate required changes on the engineering drawings.

Telemetry and Disturbance Monitoring Requirements

Telemetry and disturbance monitoring is required in all cases for Projects that will operate in the Flow-back Mode and have the capability to supply aggregate generation greater than 550 kW, but less than or equal to 2 MW to Consumers Energy. For Projects that will operate in the Non-Flow-back Mode, the requirement for telemetry will be determined on a case-by-case basis as part of the Engineering Review.

Telemetry enables Consumers Energy to operate the electric system safely and reliably under both normal and emergency conditions. Consumers Energy measures its internal load plus losses (generation) on a real time basis via an extensive telemetry system. This system sums all energy flowing into the Consumers Energy electric system from Projects interconnected to the system and from interconnections with other utilities. During system disturbances when portions of the electrical systems are out of service, it is essential to know if a Project is on line or off line to determine the proper action to correct the problem. Time saved during restoration

activities translates to fewer outages and outages of shorter duration for the Consumers Energy customers.

Consumers Energy evaluates the performance of the overall protective system for all faults on the electric system. It is critical that sufficient monitoring of the protective system is in place to determine its response. It is preferable to deploy disturbance monitoring into all Projects, but it can be expensive to deploy. Therefore, disturbance monitoring is required only for installations that already require telemetry.

The Project Developer shall provide a suitable indoor location, approved by Consumers Energy, for Consumers Energy owned, operated, and maintained Remote Terminal Unit (RTU). The location must be equipped with a 48 V or 125 V DC power supply. The Project Developer must provide the necessary phone (or alternate) and data circuits, and install a telephone (or alternate) backboard for connections to the Consumers Energy RTU and metering equipment. All phone circuits must be properly protected as detailed in IEEE Std. 487. See "Typical Meter and RTU Installation Where Telemetry is Required" in the Generator Interconnection Supplement.

When telemetry is required, the following values will be telemetered:

1. Real and reactive power flow at the PCC.
2. Voltage at the PCC.
3. The status (normal/fail) of protective relay Communication Channels. A status indication of "FAIL" indicates the Communication Channel used for relaying (i.e. transfer trip) is unable to perform its protective function.
4. The status (open/closed) of the main isolating breaker and each generating unit breaker (if the Project is composed of multiple units, a single logical (OR) status of the individual Project breaker states, indicating all Project breakers are open or any one or more Project breakers are closed, is permissible). A closed status would be indicated if any individual generator is on line.

The RTU will be equipped with "sequence of events" recording.

The Project Developer shall provide, wired to a terminal block near the RTU panel, the following general equipment Auxiliary Contacts and relay contacts:

1. An output contact of an instantaneous relay to act as a ground fault detector for faults on the Consumers Energy electric system. This relay shall be connected into the same sensing source as the ground fault protective relay required by Consumers Energy.
2. Each and every trip of an interconnection isolation device, which is initiated by any of the generator interconnection relaying schemes required by Consumers Energy.
3. Each and every trip of an interconnection isolation device, which is initiated by any of the protective systems for the generator.
4. Each and every trip or opening of an interconnecting isolation device, which is initiated by any other manual or electrical means.

5. A contact indicating the position of the Project's primary-side main breaker.
6. A contact indicating operation of the over/undervoltage relays.
7. A contact indicating operation of the under/overfrequency relay or Consumers Energy ground fault relay.
8. A contact indicating operation of the Project provided transformer bank relaying.
9. A contact indicating operation of any of the (51V) relaying.
10. A contact indicating the position of the high-side fault-clearing device.
11. A contact indicating the position of the reverse power relay, if said, relay is required by Consumers Energy.
12. The following individual contact from each individual Direct Transfer Trip receiver, required by Consumers Energy:
 - i. Loss-of-guard (LOG) alarm
 - ii. Receive-trip relay (RTX).
 - iii. Lockout relay.

If any of the functions indicated in items 2-4, 6, 7, 9, or 11 are combined into a multi-functional device, either:

1. Each of those functions must be monitored independently on the RTU, or
2. Provisions acceptable to Consumers Energy must be provided to interrogate the multi-functional device such that the operation of the individual functions may be evaluated separately.

Telemetry, when required, will be provided by Consumers Energy at the Project Developer's expense. In addition to other telemetry costs, a one-time charge will be assessed to the Project Developer for equipment and software installed at the Consumers Energy System Control Center to process the data signals.

Miscellaneous Operational Requirements

Miscellaneous requirements include synchronizing equipment for Parallel Operation, reactive requirements, standby power considerations, and system stability limitations.

Operating in Parallel

The Project Developer will be solely responsible for the required synchronizing equipment and for properly synchronizing the Project with the Consumers Energy electric system.

Voltage fluctuation at the PCC during synchronizing shall be limited per IEEE std. 1547..

The Project Developer will notify Consumers Energy prior to synchronizing to and prior to scheduled disconnection from the electric system.

These requirements are directly concerned with the actual operation of the Project with Consumers Energy:

- The Project may not commence parallel operation until approval has been given by Consumers Energy. The completed installation is subject to inspection by Consumers Energy prior to approval. Preceding this inspection, all contractual agreements must be executed by the Project Developer.
- The Project must be designed to prevent the Project from energizing into a de-energized Utility line. The Project's circuit breaker or contactor must be blocked from closing in on a de-energized circuit.
- The Project shall discontinue parallel operation with a particular service and perform necessary switching when requested by Consumers Energy for any of the following reasons:
 1. When public safety is being jeopardized.
 2. During voltage or loading problems, system emergencies, or when abnormal sectionalizing or circuit configuration occurs on the Consumers Energy system.
 3. During scheduled shutdowns of Utility equipment that are necessary to facilitate maintenance or repairs. Such scheduled shutdowns shall be coordinated with the Project.
 4. In the event there is demonstrated electrical interference (i.e. Voltage Flicker, Harmonic Distortion, etc.) to Consumers Energy customers, suspected to be caused by the Project, and such interference exceeds then current system standards, Consumers Energy reserves the right, at Consumers Energy's initial expense, to install special test equipment as may be required to perform a disturbance analysis and monitor the operation and control of the Project to evaluate the quality of power produced by the Project. In the event that no standards exist, then the applicable tariffs and rules governing electric service shall apply. If the Project is proven to be the source of the interference, and that interference exceeds Consumers Energy standards or the generally accepted industry standards, then it shall be the responsibility of the Project Developer to eliminate the interference problem and to reimburse Consumers Energy for the costs of the disturbance monitoring installation, removal, and analysis, excluding the cost of the meters or other special test equipment.
 5. When either the Project or its associated synchronizing and protective equipment is demonstrated by Consumers Energy to be improperly maintained, so as to present a hazard to the Consumers Energy electric system or its customers.
 6. Whenever the Project is operating isolated with other Utility customers, for whatever reason.

7. Whenever a loss of communication channel alarm is received from a location where a communication channel has been installed for the protection of the Consumers Energy electric system.
8. Whenever Consumers Energy notifies the Project Developer in writing of a claimed non-safety related violation of the Parallel Operating Agreement and the Project Developer fails to remedy the claimed violation within ten working days of notification, unless within that time either the Project Developer files a complaint with the MPSC seeking resolution of the dispute or the Project Developer and Utility agree in writing to a different procedure.

If the Project has shown an unsatisfactory response to requests to separate the generation from the Consumers Energy electric system, Consumers Energy reserves the right to disconnect the Project from parallel operation with the Consumers Energy electric system until all operational issues are satisfactorily resolved.

Reactive Power Control

Synchronous generators that will operate in the Flow-back Mode must be dynamically capable of providing 0.90 power factor lagging (delivering reactive power to Consumers Energy) and 0.95 power factor leading (absorbing reactive power from Consumers Energy) at the Point of Receipt. The Point of Receipt is the location where Consumers Energy accepts delivery of the output of the Project. The Point of Receipt can be the physical location of the billing meters or a location where the billing meters are not located, but adjusted for line and transformation losses.

Induction and Inverter Projects that will operate in the Flow-back Mode must provide for their own reactive needs (steady state unity power factor at the Point of Receipt). To obtain unity power factor, the Induction or Inverter Project can:

1. Install a switchable VAR supply source to maintain unity power factor at the Point of Receipt;
or
2. Provide Consumers Energy with funds to install a VAR supply source equivalent to that required for the Project to attain unity power factor at the Point of Receipt at full output.

There are no interconnection reactive power capability requirements for Synchronous, Induction, and Inverter Projects that will operate in the Non Flow-back Mode. Consumers Energy existing rate schedules, incorporated herein by reference, contain power factor adjustments based on the power factor of the metered load at these facilities.

Standby Power

Standby power will be provided under the terms of an approved rate set forth in Consumers Energy Standard Rules and Regulations. The Project Developer should be aware that to qualify for Standby Rates, a separate meter must be installed at the generator.

If outside of the Consumers Energy franchise area, it will be the Project Developer's responsibility to arrange contractually and technically for the supply of its facility's standby, maintenance, and any supplemental power needs.

System Stability and Site Limitations

The Stiffness Ratio is the combined three-phase short circuit capability of the Project and the utility system divided by the short circuit capability of the Project measured at the PCC. A stability study may be required for Projects with a Stiffness Ratio of less than 40. Five times the generator rated kVA will be used as a proxy for short circuit current contribution for induction generators. For synchronous Projects, with a Stiffness Ratio of less than 40, Consumers Energy requires special generator trip schemes or loss of synchronism (out-of-step) relay protection. If the apparent voltage flicker from a loss-of-synchronism condition exceeds 5%, an out-of-step relay will be required. This type of protection is typically applied at the PCC and trips the entire Project off-line, if instability is detected, to protect the Consumers Energy electric system and its customers. If the Project Developer chooses not to provide for mitigation of unacceptable voltage flicker (above five percent), Consumers Energy may disallow the interconnection of the Project or require a new dedicated interconnection at the Project Developer's expense.

The Project Developer is responsible for evaluating the consequences of unstable generator operation or voltage transients on Project equipment and determining, designing, and applying any relaying which may be necessary to protect that equipment. This type of protection is typically applied on individual generators to protect the Project facilities.

Consumers Energy will determine if operation of the Project will create objectionable voltage flicker and/or disturbances to other Consumers Energy customers and develop any required mitigation measures at the Project Developer's expense.

Revenue Metering Requirements

Consumers Energy will own, operate, and maintain the billing metering equipment at the Project Developer's expense. The billing metering will meter both real and reactive interconnection flows between the Project and the Consumers Energy electric system. Where applicable, separate metering of station power may be required to accurately meter the generation facility load when the Project is off-line.

Special billing metering will be required for Projects operating in the Flow-back Mode. If telemetering is required, the billing metering will be included as part of the telemetering installation. Ground fault protection for this circuit may be required, and coordination with the telephone company and all associated costs will be by Project Developer.

The Project Developer shall provide a suitable indoor location, approved by Consumers Energy, for Consumers Energy's owned, operated, and maintained billing metering.

The Project Developer shall provide authorized employees and agents of Consumers Energy access to the premises at all times to install, turn on, disconnect, inspect, test, read, repair, or remove the metering equipment. The Project Developer may, at its option, have a representative witness this work.

The metering installations for Flow-back operation shall be constructed in accordance with the practices, which normally apply to the construction of metering installations for commercial, industrial, or other customers with demand recording equipment. At a minimum three meters will be required; two at the PCC, one import and one export and one at the generator.

Consumers Energy shall supply to the Project Developer all required metering equipment and the standard detailed specifications and requirements relating to the location, construction, and access of the metering installation and will provide consultation pertaining to the meter installation as required. Consumers Energy will endeavor to coordinate the delivery of these materials with the Project Developer's installation schedule during normal scheduled business hours.

The Project Developer shall provide a mounting surface for the meters, recorders, connection cabinets, a housing for the instrument transformers, a conduit for the conductors between the instrument transformer secondary windings and the meter connection cabinets, and a conduit for the communication links, if required. All of this equipment must meet Consumers Energy specifications and requirements.

The responsibility for the installation of the equipment is shared between Consumers Energy and the Project Developer, with the Project Developer generally installing all of the equipment on its side of the PCC, including instrument transformers, cabinets, conduits, and mounting surfaces. Consumers Energy, or its agents, shall install the meters, recorders, and communication links. Consumers Energy will endeavor to coordinate the installation of these items with the Project Developer's schedule.

Communication Circuits

The Project Developer is responsible for ordering and acquiring the telephone circuit required for the Project Interconnection. The Project Developer will assume all installation, operating, and maintenance costs associated with the telephone circuits, including the monthly charges for the telephone lines and any rental equipment required by the local telephone provider. However, at Consumers Energy discretion, Consumers Energy may select an alternative communication method, such as wireless communications. Regardless of the method, the Project Developer will be responsible for all costs associated with the material, installation and maintenance, whereas Consumers Energy will be responsible to define the specific communication requirements.

Consumers Energy will cooperate and provide utility information necessary for proper installation of the telephone (or alternate) communication circuits upon written request.

A dedicated communication circuit is required for access to the billing meter by Consumers Energy. When DTT is required, a modular RJ-11 jack must also be installed within six feet of the billing metering equipment, to allow Consumers Energy to use this circuit for voice communication with personnel performing master station checkout of the RTU. This dial-up voice-grade circuit shall be a local telephone company provided business measured line without dial-in or dial-out call restrictions.

If DTT is required, a separate dedicated 4-wire, Class A, Data Circuit must be installed and protected as specified by the local telephone Utility for each DTT receiver and for the RTU. The circuit must be installed in rigid metallic conduit from the RTU and each DTT receiver to the point of connection to the telephone Utility equipment. Wall space must be provided for adjacent mounting next to the telephone board, of the billing metering panel and a telemetry enclosure. The billing metering panel is typically 60 inches high by 48 inches wide and the telemetry

enclosure is typically 24 inches high by 24 inches wide. A clear space of 4.5 feet in front of this equipment is required to permit maintenance and testing. A review of each installation shall be made to determine the location and space requirements most agreeable to Consumers Energy and the Project Developer.

APPENDIX A
INTERCONNECTION PROCESS FLOW DIAGRAM

Interconnection Process Flow Diagram

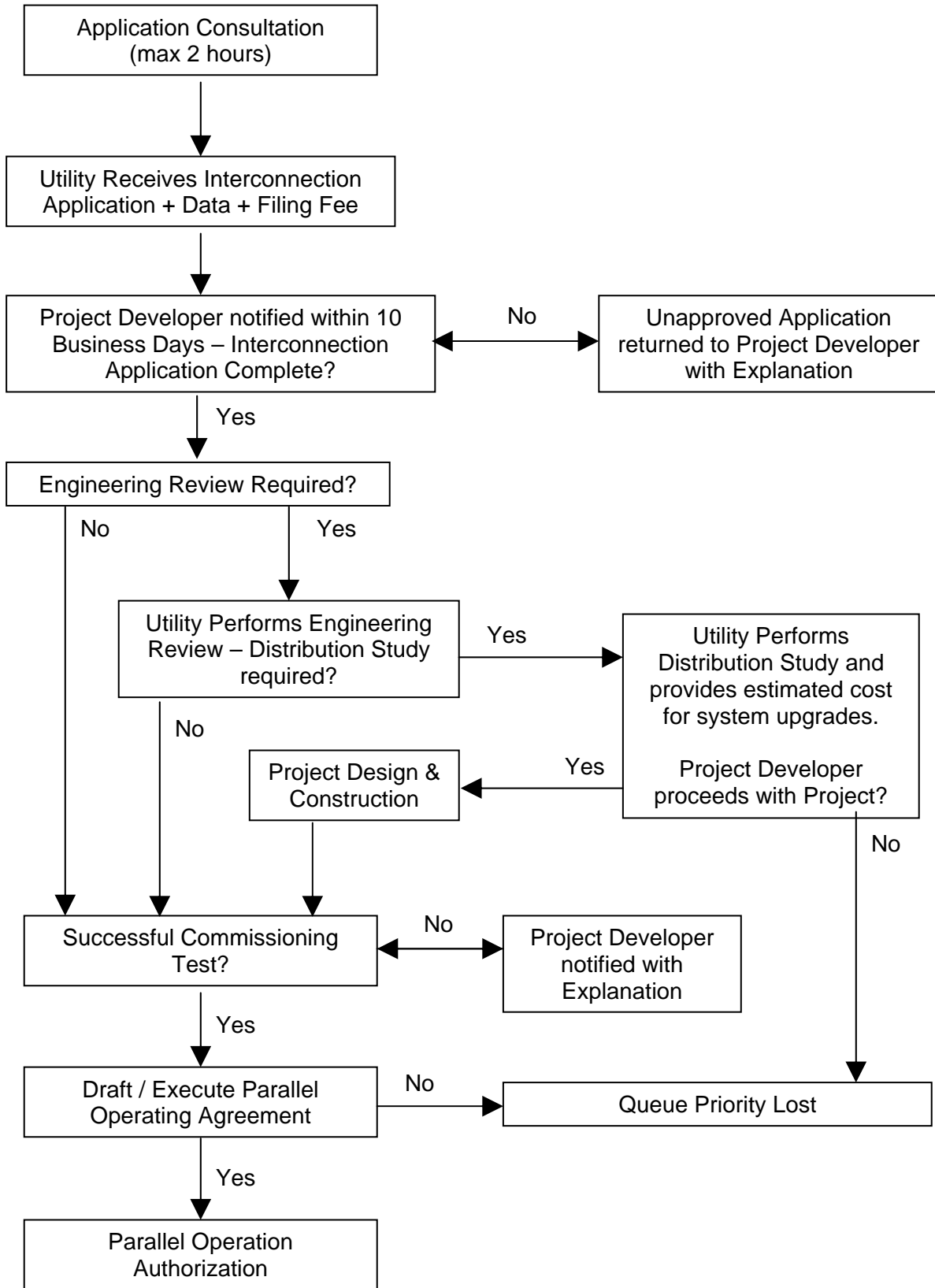

APPENDIX B
INTERCONNECTION FEES AND TIMELINE

Interconnection Table – Project Developer Costs

	Application Review	Engineering Review	Distribution Study	Distribution Upgrades	Testing & Inspection
Category 4	\$250	Actual	Actual	Actual	Actual

Interconnection Timeline – Working Days

	Application Complete	Application Review	Engineering Study Completion	Distribution Study Completion	Distribution Upgrades	Testing & Inspection
Category 4	10	10	25	45 *	Mutually Agreed On	10

* Unless a different time period is mutually agreed upon.

APPENDIX C
PROCEDURE DEFINITIONS

Alternative electric supplier (AES): as defined in section 10g of 2000 PA 141, MCL 460.10g

Alternative electric supplier net metering program plan: document supplied by an AES that provides detailed information to an applicant about the AES's net metering program.

Applicant: Legally responsible person applying to an electric utility to interconnect a project with the electric utility's distribution system or a person applying for a net metering program. An applicant shall be a customer of an electric utility and may be a customer or an AES.

Application Review: Review by the electric utility of the completed application for interconnection to determine if an engineering review is required.

Area Network: A location on the distribution system served by multiple transformers interconnected in an electrical network circuit.

Category 1: An inverter based project of 20kW or less that uses equipment certified by a nationally recognized testing laboratory to IEEE 1547.1 testing standards and in compliance with UL 1741 scope 1.1A.

Category 2: A project of greater than 20 kW and not more than 150 kW.

Category 3: A project of greater than 150 kW and not more than 550 kW.

Category 4: A project of greater than 550 kW and not more than 2 MW.

Category 5: A project of greater than 2 MW.

Certified equipment: A generating, control, or protective system that has been certified as meeting acceptable safety and reliability standards by a nationally recognized testing laboratory in conformance with UL 1741.

Commission: The Michigan Public Service Commission

Commissioning test: The procedure, performed in compliance with IEEE 1547.1, for documenting and verifying the performance of a project to confirm that the project operates in conformity with its design specifications.

Customer: A person who receives electric service from an electric utility's distribution system or a person who participates in a net metering program through an AES or electric utility.

Customer-generator: A person that uses a project on-site that is interconnected to an electric utility distribution system.

Distribution system: The structures, equipment, and facilities operated by an electric utility to deliver electricity to end users, not including transmission facilities that are subject to the jurisdiction of the federal energy regulatory commission.

Distribution system study: A study to determine if a distribution system upgrade is needed to accommodate the proposed project and to determine the cost of an upgrade if required.

Electric provider: Any person or entity whose rates are regulated by the commission for selling electricity to retail customers in the state.

Electric utility: Term as defined in section 2 of 1995 PA 30, MCL 460.562.

Eligible electric generator: A methane digester or renewable energy system with a generation capacity limited to the customer's electrical need and that does not exceed the following:

- 150 kW of aggregate generation at a single site for a renewable energy system
- 550 kW of aggregate generation at a single site for a methane digester

Engineering Review: A study to determine the suitability of the interconnection equipment including any safety and reliability complications arising from equipment saturation, multiple technologies, and proximity to synchronous motor loads.

Full retail rate: The power supply and distribution components of the cost of electric service. Full retail rate does not include system access charge, service charge, or other charge that is assessed on a per meter basis.

IEEE: Institute of Electrical and Electronics Engineers

IEEE 1547: IEEE "Standard for Interconnecting Distributed Resources with Electric Power Systems"

IEEE 1547.1: IEEE "Standard Conformance Test Procedures for Equipment Interconnecting Distributed Resources with Electric Power Systems"

Interconnection: The process undertaken by an electric utility to construct the electrical facilities necessary to connect a project with a distribution system so that parallel operation can occur.

Interconnection procedures: The requirements that govern project interconnection adopted by each electric utility and approved by the commission.

kW: kilowatt

kWh: kilowatt-hours

Material modification: A modification that changes the maximum electrical output of a project or changes the interconnection equipment including the following:

- Changing from certified to non certified equipment
- Replacing a component with a component of different functionality or UL listing.

Methane digester: A renewable energy system that uses animal or agricultural waste for the production of fuel gas that can be burned for the generation of electricity or steam.

Modified net metering: A utility billing method that applies the power supply component of the full retail rate to the net of the bidirectional flow of kWh across the customer interconnection with the utility distribution system during a billing period or time-of-use pricing period.

MW: megawatt

Nationally recognized testing laboratory: Any testing laboratory recognized by the accreditation program of the U.S. department of labor occupational safety and health administration.

Parallel operation: The operation, for longer than 100 milliseconds, of a project while connected to the energized distribution system.

Project: Electrical generating equipment and associated facilities that are not owned or operated by an electric utility.

Renewable energy credit (REC): A credit granted pursuant to the commission's renewable energy credit certification and tracking program in section 41 of 2008 PA 295, MCL 460.1041.

Renewable energy resource: Term as defined in section 11(i) of 2008 PA 295, MCL 460.1011(i)

Renewable energy system: Term as defined in section 11(k) of 2008 PA 295, MCL 460.1011(k).

Spot network: A location on the distribution system that uses 2 or more inter-tied transformers to supply an electrical network circuit.

True net metering: A utility billing method that applies the full retail rate to the net of the bidirectional flow of kW hours across the customer interconnection with the utility distribution system, during a billing period or time-of-use pricing period.

UL: Underwriters Laboratory

UL 1741: The "Standard for Inverters, Converters, Controllers and Interconnection System Equipment for Use With Distributed Energy Resources."

UL 1741 scope 1.1A: Paragraph 1.1A contained in chapter 1, section 1 of UL 1741.

Uniform interconnection application form: The standard application forms, approved by the commission under R 460.615 and used for category 1, category 2, category 3, category 4, and category 5 projects.

Uniform interconnection agreement: The standard interconnection agreements approved by the commission under R 460.615 and used for category 1, category 2, category 3, category 4, and category 5 projects.

Uniform net metering application: The net metering application form approved by the commission under R 460.642 and used by all electric utilities and AES.

Working days: Days excluding Saturdays, Sundays, and other days when the offices of the electric utility are not open to the public.

APPENDIX D

INTERCONNECTION APPLICATION



GENERATION INTERCONNECTION APPLICATION
Category 4
For All Projects with Aggregate Generator Output of
More Than 550 kW but Less Than or Equal to 2 MW

ELECTRIC UTILITY CONTACT INFORMATION		FOR OFFICE USE ONLY	
<p align="center">Consumers Energy Interconnection Coordinator 1945 West Parnall Road (Room P24-332B) Jackson, MI 49201 (517)788-1432 Net Metering E-mail: net_metering@cmsenergy.com</p>		Application Number	
		Date and Time Application Received	
CUSTOMER / ACCOUNT INFORMATION			
Electric Utility Customer Information (As shown on utility bill)			
Customer Name (Last, First, Middle)		Customer Mailing Address	
Customer Phone Number ()		Customer E-mail Address (Optional)	
INSTALLATION INFORMATION			
Project Developer/Single Point of Contact			
Name	Phone Number ()	Fax Number ()	
Address			
E-Mail Address			
Project Site Address			
GENERATION SYSTEM SITE INFORMATION			
Project Type (Base load, Peaking, Intermediate)		Energization Date for Project Interconnection Facilities	
First Parallel Operation Date for Testing		Project Commercial Operation Date	
Estimated Project Cost		Operation Mode	
Attached Customer's Proof of General Liability Insurance for a minimum of \$1,000,000 Page # _____			
(Per MPSC Order in Case No. U-15787 – Customer must maintain a minimum of \$1,000,000 General Liability Insurance.)			
Attached Site Plan Page # _____			
Attached Electrical One-Line Drawing Page # _____			
(Per MPSC Order in Case No. U-15787 – The One-Line Drawing must be signed and sealed by a licensed professional engineer, licensed in the State of Michigan.)			
<ul style="list-style-type: none"> • See Page 6 for sample Site Plan • See Page 7 for sample of Synchronous Generator Electrical One-Line Drawing • See Page 8 for sample of Induction Generator Electrical One-Line Drawing 			
Attached Specification for Equipment Page # _____			

ISOLATING TRANSFORMER(S) BETWEEN GENERATOR(S) AND UTILITY

Transformer Model Number	Transformer Manufacturer
Rated kV and connection (delta, wye, wye-gnd) of each winding	kVA of each winding (kW)
BIL of each winding	Fixed taps available for each winding (kW)
Positive/Negative range for any LTC windings	%Z impedance on transformer self cooled rating (kW)
Percent Excitation current at rated kV	Load Loss Watts at full load or X/R ratio (kW)

**SYNCHRONOUS, INDUCTION AND INVERTER GENERATOR - BASED SYSTEMS
(Must complete Page 3, Page 4 or Page 5 and attach Electrical One-Line Drawing)**

The following information on these system components shall appear on the Electrical One-Line Drawing:

- Breakers – Rating, location and normal operating status (open or closed)
- Buses – Operating voltage
- Capacitors – Size of bank in Kvar
- Circuit Switchers – Rating, location and normal operating status (open or closed)
- Current Transformers – Overall ratio, connected ratio
- Fuses – Normal operating status, rating (Amps), type
- Generators – Capacity rating (kVA), location, type, method of grounding
- Grounding Resistors – Size (ohms), current (Amps)
- Isolating Transformers – Capacity rating (kVA), location, impedance, voltage ratings, primary and secondary connections and method of grounding
- Potential Transformers – Ratio, connection
- Reactors – Ohms/phase
- Relays – Types, quantity, IEEE device number, operator lines indicating the device initiated by the relays
- Switches – Location and normal operating status (open or closed), type, rating
- Tagging Point – Location, identification

Manufacturer	Model Name	Model Number
--------------	------------	--------------

CUSTOMER AND PROJECT DEVELOPER/CONTRACTOR SIGNATURES AND FEES

Attached \$250 Interconnection Application Fee

Check # _____ Money Order # _____

Sign and Return Completed Application with Application Fee to Electric Utility Contact

To the best of my knowledge, all the information provided in this application form is complete and correct.

Customer Signature: _____ Date _____

Project Developer/Contractor Signature (if applicable): _____ Date _____

Note: Refer to the applicable "Michigan Electric Utility Generator Interconnection Requirements" for a detailed explanation of the Interconnection Process, Fees, Timelines, and Technical Requirements.

INVERTER GENERATORS

GENERATOR INFORMATION

System Type (Solar, Wind, Biomass, Methane Digester, etc)	Generation Nameplate Rating (kW or MVA)
AC Operation Voltage	Manufacturer
Model (Name/Number)	Attached Grid Configuration Page # _____

SYNCHRONOUS GENERATORS**GENERATOR INFORMATION**

Generator Nameplate Voltage	Generator Nameplate Watts or Volt-Amperes
Generator Nameplate Power Factor (pf)	RPM

TECHNICAL INFORMATION

Minimum and Maximum Acceptable Terminal Voltage
Direct Axis Reactance (saturated)
Direct Axis Reactance (unsaturated)
Quadrature Axis Reactance (unsaturated)
Direct Axis Transient Reactance (saturated)
Direct Axis Transient Reactance (unsaturated)
Quadrature Axis Transient Reactance (unsaturated)
Direct Axis Sub-Transient Reactance (saturated)
Direct Axis Sub-Transient Reactance (unsaturated)
Leakage Reactance
Direct Axis Transient Open Circuit Time Constant
Quadrature Axis Transient Open Circuit Time Constant
Direct Axis Sub-Transient Open Circuit Time Constant
Quadrature Axis Sub-Transient Open Circuit Time Constant
Open Circuit Saturation Curve
Reactive Capability Curve Showing Overexcited and Underexcited Limits (Reactive Information if Non-Synchronous)
Excitation System Block Diagram with Values for Gains and Time Constants (Laplace Transforms)
Short Circuit Current Contribution From Generator at the Point of Common Coupling
Rotating Inertia of Overall Combination Generator, Prime Mover, Couplers and Gear Drives
Station Power Load When Generator is Off-Line, Watts, pf
Station Power Load During Start-Up, Watts, pf
Station Power Load During Operation, Watts, pf

INDUCTION GENERATORS**GENERATOR INFORMATION**

Generator Nameplate Voltage	Generator Nameplate Watts or Volt-Amperes
Generator Nameplate Power Factor (pf)	RPM

TECHNICAL INFORMATION

Synchronous Rotational Speed	Rotation Speed at Rated Power
Slip at Rated Power	
Minimum and Maximum Acceptable Terminal Voltage	
Motoring Power (kW)	
Neutral Grounding Resistor (If Applicable)	
I ² 2t or K (Heating Time Constant)	
Rotor Resistance	
Stator Resistance	
Stator Reactance	
Rotor Reactance	
Magnetizing Reactance	
Short Circuit Reactance	
Exciting Current	
Temperature Rise	
Frame Size	
Design Letter	
Reactive Power Required in Vars (No Load)	
Reactive Power Required in Vars (Full Load)	
Short Circuit Current Contribution from Generator at the Point of Common Coupling	
Rotating Inertia, H in Per Unit on kVA Base, of Overall Combination Generator, Prime Mover, Couplers and Gear Drives	
Station Power Load When Generator is Off-Line, Watts, pf	
Station Power Load During Start-Up, Watts, pf	
Station Power Load During Operation, Watts, pf	

SAMPLE SITE PLAN – PROVIDED FOR REFERENCE ONLY

SITE PLAN	
Applicant	
Address	
City/Town	
Signature	

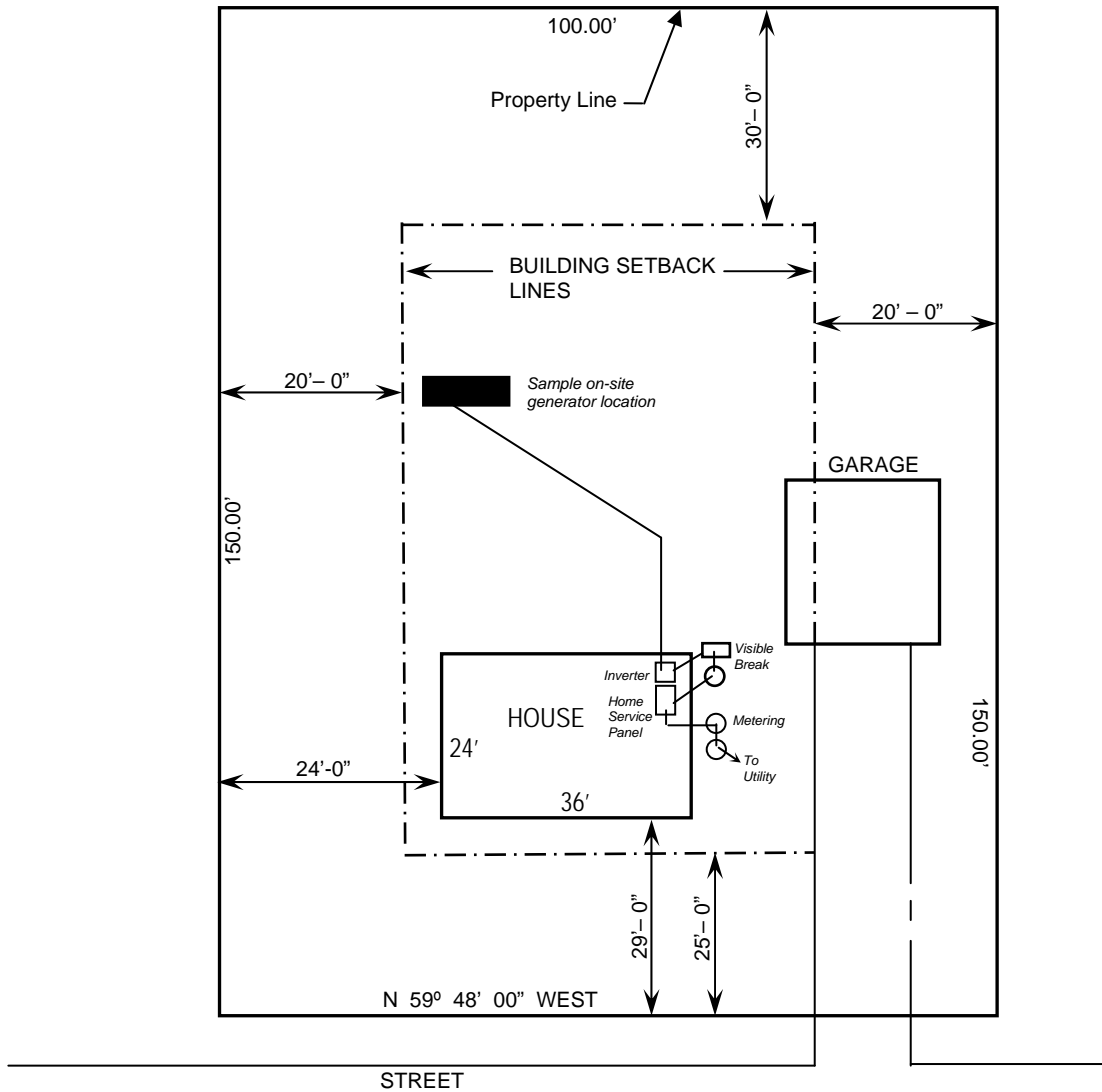

Weblink to State of Michigan / Plats:

http://www.cis.state.mi.us/platmaps/sr_subs.asp

Note: Legible hand drawn site plans are acceptable

SAMPLE ELECTRICAL ONE-LINE DRAWING – PROVIDED FOR REFERENCE ONLY TYPICAL ISOLATION AND FAULT PROTECTION FOR SYNCHRONOUS GENERATOR

ONE-LINE DRAWING	
Licensed PE/Contractor	PE/Contractor License Number
PE/Contractor Address	PE/Contractor Signature

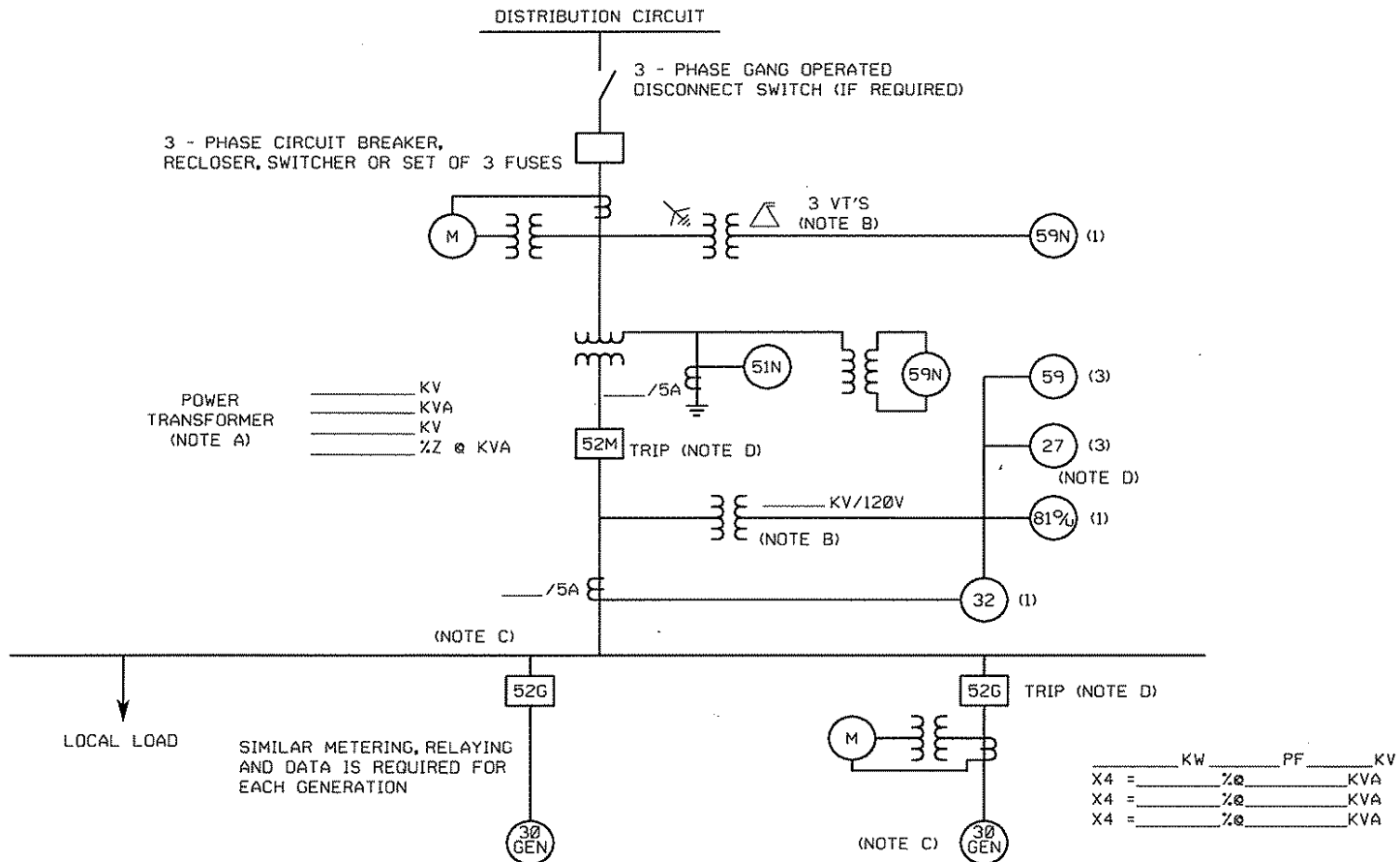

LEGEND

- 27 Undervoltage
- 32 Reverse Power (Not Required for Flow-Back)
- 51N Neutral overcurrent (required for grounded secondary)
- 59 Overvoltage
- 59N Zero sequence overvoltage (assuming ungrounded secondary on power transformer)
- 81o/u Over/Underfrequency

NOTES

- A) See technical requirements for permissible connection configurations and protection. Transformer connections proposed shall be shown on the one-line drawing by the Project Developer. Transformer connection and secondary grounding to be approved by Utility.
- B) Protection alternatives for the various acceptable transformer connections are shown. Only one protection alternative will ultimately be used, depending on the actual transformer winding connections. VT's for 59, 27, 81o/u and 32 are shown connected on the primary (Project side) of the power transformer, but may instead be connected on the secondary (Utility side). VT's are required on the secondary of the power transformer if a 59N is required for an ungrounded secondary connection. IEEE std 1547 requirements for voltage and frequency must be met at the PCC. IEEE Std. 1547 permits the VT's to be connected at the point of generator connection in certain cases.
- C) Main breaker protection, generator protection and synchronizing equipment are not shown.
- D) Trip of all 52G breakers or the 52M breaker is acceptable, depending upon whether the Project Developer wants to serve its own isolated load after loss of Utility service.

SAMPLE ELECTRICAL ONE-LINE DRAWING – PROVIDED FOR REFERENCE ONLY TYPICAL ISOLATION AND FAULT PROTECTION FOR INDUCTION GENERATOR

ONE-LINE DRAWING	
Licensed PE/Contractor	PE/Contractor License Number
PE/Contractor Address	PE/Contractor Signature

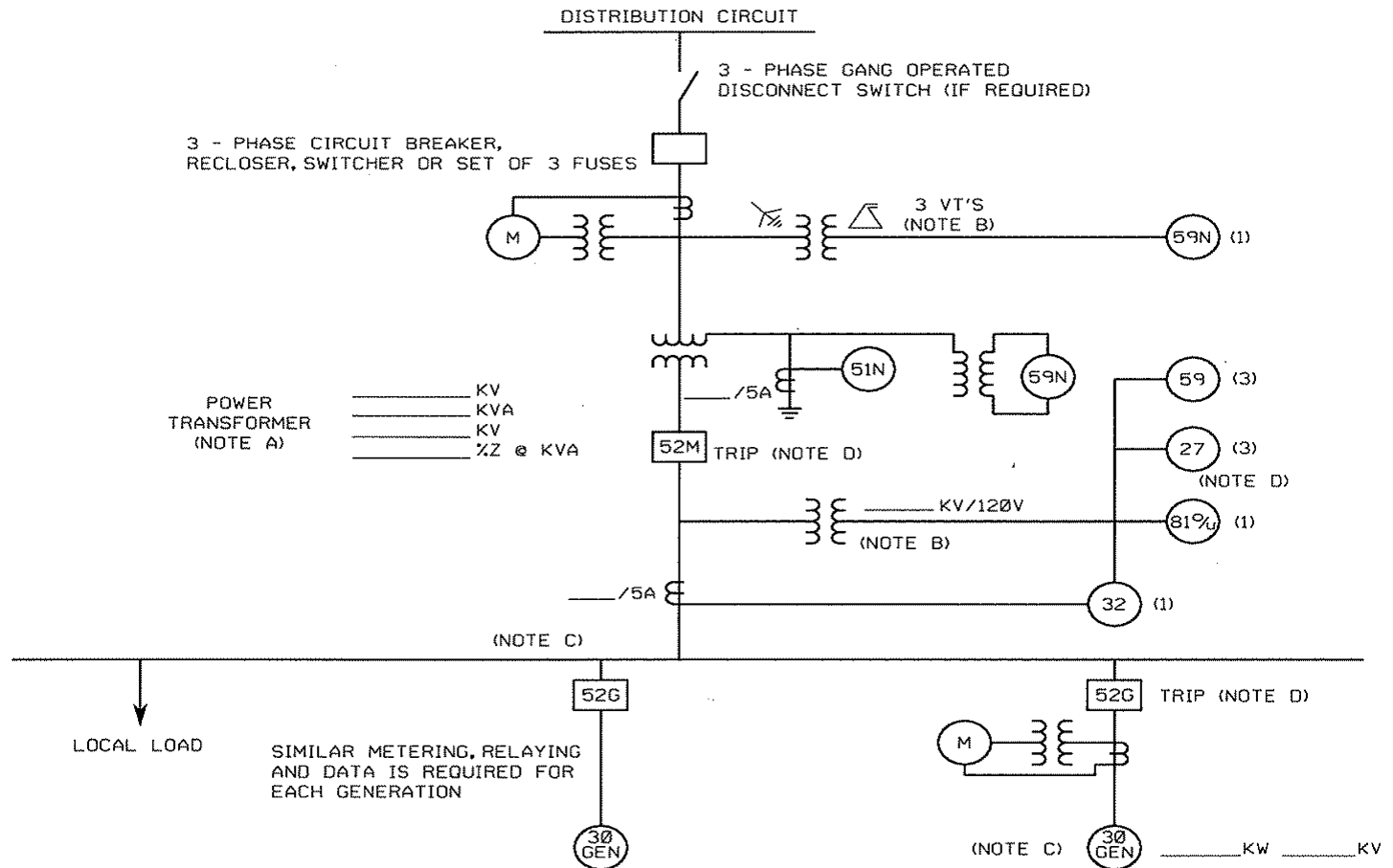

LEGEND

- 27 Undervoltage
- 32 Reverse Power (Not Required for Flow-Back)
- 51N Neutral overcurrent (required for grounded secondary)
- 59 Overvoltage
- 59N Zero sequence overvoltage (assuming ungrounded secondary on power transformer)
- 81o/u Over/Underfrequency

NOTES

- A) See technical requirements for permissible connection configurations and protection. Transformer connections proposed shall be shown on the one-line drawing by the Project Developer. Transformer connection and secondary grounding to be approved by Utility.
- B) Protection alternatives for the various acceptable transformer connections are shown. Only one protection alternative will ultimately be used, depending on the actual transformer winding connections. VT's for 59, 27, 81o/u and 32 are shown connected on the primary (Project side) of the power transformer, but may instead be connected on the secondary (Utility side). VT's are required on the secondary of the power transformer if a 59N is required for an ungrounded secondary connection. IEEE std 1547 requirements for voltage and frequency must be met at the PCC. IEEE Std. 1547 permits the VT's to be connected at the point of generator connection in certain cases.
- C) Main breaker protection, generator protection and synchronizing equipment are not shown.
- D) Trip of all 52G breakers or the 52M breaker is acceptable, depending upon whether the Project Developer wants to serve its own isolated load after loss of Utility service.

APPENDIX E

ENGINEERING REVIEW AND DISTRIBUTION STUDY AGREEMENTS

Consumers Energy
[Project]
[Engineering Review] [Distribution Study] Agreement for
Generator Interconnection Project

WHEREAS, proposals to construct or upgrade a Project which will be operated in parallel with and interconnected with Consumers Energy ("Consumers") electric system must be reviewed by Consumers to determine how it will impact Consumers' electric system.

WHEREAS, on _____ Consumers received from _____ ("Project Developer") a Generator Interconnection Application.

Project Number		Project Size	
----------------	--	--------------	--

WHEREAS Consumers has determined that [an Engineering Review] [a Distribution Study] is necessary to determine whether Consumers' electric system can accommodate the requested interconnection.

NOW, THEREFORE, in consideration of the mutual covenants and agreements herein set forth, Consumers and the Project Developer agree as follows:

1. Consumers shall complete [an Engineering Review] [a Distribution Study] in accordance with Consumers' Generator Interconnection Requirements and this Agreement.
2. Consumers is permitted by the Michigan Public Service Commission to charge the Project Developer \$ _____ for the [Engineering Review] [Distribution Study].
3. The Project Developer is to return this executed [Engineering Review] [Distribution Study] Agreement and payment to Consumers. The interconnection process will not proceed until the fully executed [Engineering Review] [Distribution Study] Agreement and payment is received.
4. Consumers shall supply a copy of the completed [Engineering Review] [Distribution Study] to the Project Developer.

5. Any notice or request made to or by either Party regarding this Agreement shall be made to the representative of the other Party, or its designated agent, as indicated below.

Consumers Energy

Project Developer

Name _____

Company _____

Address 1 _____

Address 2 _____

IN WITNESS WHEREOF, the Parties have caused this [Engineering Review] [Distribution Study] Agreement to be executed by their respective authorized officials.

By:

By:

(Signature)

(Signature)

(Typewritten or Printed Name)

(Typewritten or Printed Name)

Title

Title

Date

Date

APPENDIX F

INTERCONNECTION AND PARALLEL OPERATING AGREEMENT



**GENERATOR INTERCONNECTION & OPERATING AGREEMENT
FOR CATEGORY 3 – 5 PROJECTS
WITH AGGREGATE GENERATOR OUTPUT OF GREATER THAN 150 kW
BETWEEN CONSUMERS ENERGY COMPANY
AND
(PROJECT DEVELOPER NAME)**

GENERATOR INTERCONNECTON & OPERATING AGREEMENT (hereinafter, this Agreement), is made and entered into on (insert date of last signature from page 11), (hereinafter, the Effective Date), between CONSUMERS ENERGY, a Michigan corporation, with offices located at One Energy Plaza, Jackson, MI 49201, herein termed "Consumers", and (Project Developer Name) with offices located at (Address, City, State, ZIP), herein termed "Project Developer." Consumers and Project Developer are hereinafter sometimes referred to individually as "Party" and collectively as "Parties" where appropriate.

WITNESSETH:

WHEREAS, Consumers owns electric facilities and is engaged in the generation, purchase, distribution and sale of electric energy in the State of Michigan; and

WHEREAS, Project Developer intends to construct and own a _____ plant, known as the _____ Generating Plant, herein termed "Project", with a generator design capacity nameplate rating not to exceed _____ MW and located at (Address, City, State, ZIP); and

WHEREAS, This Agreement does not address the sale of electricity to or from Consumers; and

WHEREAS, The Parties desire to enter into this Agreement for the purposes, among others, of (a) describing (i) the facilities and associated appurtenances to interconnect the Project to Consumers' distribution system, including defining the Point of Delivery and Interconnection Point, (ii) the facilities required for providing and regulating reactive power supply (kilovars) at the Project, and (iii) any modifications and additions necessary on Consumers' distribution system as a result of the operation of the Project; (b) establishing the ownership interests of Consumers and Project Developer in such facilities; (c) establishing the respective obligations and rights of the Parties with respect to the procurement, construction, installation, operation and maintenance of such facilities.

NOW, THEREFORE, in consideration of the mutual covenants and agreements herein set forth, the Parties hereto agree as follows:

SECTION 1
INTERCONNECTION FACILITIES

1.1 General

The Parties shall provide, as specified in this Section 1, certain facilities and associated appurtenances required to interconnect the Project to Consumers' distribution system, consistent with the Michigan Electric Utility Generator Interconnection Requirements. Such facilities and associated appurtenances include, but shall not be limited to, interconnection, transformation, switching, control, metering, telemetering, protective relaying equipment (such protective relaying equipment required by Consumers or Project Developer to protect Consumers' distribution system, its customers, and the Project from electrical faults occurring at the Project or on Consumers' distribution system or on the systems of others to which Consumers' distribution system is directly or indirectly connected) and any necessary additions or reinforcements by Consumers to Consumers' distribution system required as a result of the interconnection of the Project to Consumers' distribution system. The facilities and associated appurtenances described in Exhibit 1 – Scope of Facilities, Subsections 1.2, "Project Developer's Interconnection Facilities," and 1.3, "Consumers' Interconnection Facilities," are hereinafter sometimes referred to as the "Interconnection Facilities." Project Developer shall be responsible for the cost of the Interconnection Facilities, unless otherwise specified in this Agreement.

The Project, configured as discussed in this Agreement and depicted in Exhibit 2 – Wiring Diagram, will be comprised of _____ generators with a total generation output of _____ MW, which can be connected to Consumers' distribution system as described herein. In the future, if the Project Developer desires to install additional generating units at this present location, the Project Developer must submit a written application to Consumers. Consumers will evaluate its distribution system to determine, in its sole discretion, if conditions at that time will allow said system to support additional capacity.

In the event future changes in (a) the design or operation of the Project, (b) Federal, State or local laws, regulations, ordinances or codes, (c) Project Developer's requirements (such as additional generators located at the site location identified above) or (d) Consumers' requirements necessitate additional facilities or modifications to the then existing Interconnection Facilities, the Parties shall undertake such additions or modifications as may be necessary. Before undertaking such future additions or modifications, the Parties shall consult, develop plans and coordinate schedules of activities so as to minimize disruption of the Interconnection Facilities and Consumers' distribution system. The cost of such future additions or modifications to the Interconnection Facilities shall be borne by the Project Developer, unless agreed upon otherwise at the time. The ownership, operation and maintenance responsibilities for any such future additions or modifications shall be made consistent with the responsibilities allocated in this Agreement.

1.2 Project Developer's Interconnection Facilities

Project Developer's Interconnection Facilities and associated appurtenances are described in Subsection 1.2 of Exhibit 1 – Scope of Facilities.

Project Developer shall bear the cost of its Project unless otherwise specified in this Agreement. Project Developer shall be solely responsible for all permits, zoning reviews, and other matters associated with obtaining rights from any governmental body or agency to construct its Project. Prior to Consumers beginning construction of its Interconnection Facilities, Project Developer shall provide a copy of all necessary documents granting Project Developer the right to construct its Project.

1.3 Consumers' Interconnection Facilities

Consumers' Interconnection Facilities and associated appurtenances are described in Subsection 1.3 of Exhibit 1 – Scope of Facilities.

Project Developer shall bear the cost of Consumers' Interconnection Facilities unless otherwise specified in this Agreement. Consumers shall be responsible for all permits, zoning reviews, and other matters associated with obtaining rights from any governmental body or agency to construct its Interconnection Facilities. Project Developer shall reimburse Consumers for all costs associated with the installation and connection of Consumers' Interconnection Facilities. Project Developer shall solely assume the risk that Consumers may be unable to complete its Interconnection Facilities due to factors beyond its reasonable control.

1.4 **Easements and Permits**

If necessary, prior to the installation of the Interconnection Facilities, Consumers will acquire required permits and necessary easements for its Interconnection Facilities. These easements / permits may include, but shall not be limited to, rights of ingress and egress, rights to clear trees, and all necessary rights-of-way for installation and maintenance of Interconnection Facilities. The Project Developer shall reimburse Consumers for the costs and expenses Consumers incurs in acquiring such easements / permits.

1.5 **Relocation by Project Developer**

If at any time the Project Developer requires Consumers' Interconnection Facilities located on its premises to be relocated on such premises, Consumers shall, at Project Developer's expense and upon its request, relocate the same or give permission for Project Developer to relocate the same. Project Developer shall provide Consumers with all necessary easement rights as required for the Interconnection Facilities located on Project Developer's premises.

SECTION 2 **DESIGN AND CONSTRUCTION OF THE INTERCONNECTION FACILITIES**

2.1 **Authority for Construction**

Except as provided in the following paragraph, Project Developer will have sole authority to manage, design, supervise, construct, procure materials for, control and will take all steps which it deems necessary or appropriate for the installation of the Interconnection Facilities required pursuant to Subsection 1.2, "Project Developer's Interconnection Facilities."

The design, specifications, installation and construction of the Interconnection Facilities required pursuant to Subsection 1.2 shall be in accordance with standards no less stringent than those used by Consumers for its own distribution voltage level installations and shall be inspected and commented on by Consumers prior to being placed into initial operation. However, Consumers has no liability, obligation or responsibility with respect to such design, plans, specifications, installation or construction regardless of its inspection and comment thereon. Inspection of and comments by Consumers shall not relieve Project Developer of any of its obligations under this Agreement.

Consumers shall exercise sole authority to manage, design, supervise, construct, procure materials for, control and take all steps which it deems necessary or appropriate for the installation and connection of the Interconnection Facilities required pursuant to Subsection 1.3, "Consumers' Interconnection Facilities."

2.2 **Interconnection of the Project**

Interconnection of the Project to Consumers' distribution system shall be made after the following conditions have been satisfied:

- 2.2.1 Both Parties have declared their Interconnection Facilities ready for service;
- 2.2.2 Project Developer has met the design, specifications, installation and construction requirements of the second paragraph of Subsection 2.1, Authority for Construction;
- 2.2.3 Project Developer has provided adequate protective equipment to protect the equipment and service of Consumers from damage or interruption from electrical faults occurring at the Project;
- 2.2.4 Consumers has tested and accepted the billing meters and associated telemetry for the collection of the metered data required pursuant to Exhibit 1 – Scope of Facilities, Subsection 1.3;
- 2.2.5 Project Developer and Consumers have agreed to a procedure to describe the process (i) for switching and tagging the interconnection facilities for workers' protection during periods when such equipment must be removed from service and (ii) for returning the equipment to service. Both Parties agree to follow the procedure for disconnecting and re-connecting the interconnection as outlined in Appendix F of the appropriate Michigan Electric Utility Generator Interconnection Requirements document;
- 2.2.6 If the Project Developer requires backup power from Consumers, the Project Developer shall be responsible for contracting with Consumers for the delivery of said backup power. The Project Developer shall provide Consumers satisfactory evidence that it has purchased the resources to supply backup power pursuant to Subsection 6.6, Project Backup Power; and
- 2.2.7 Project Developer has reimbursed Consumers for all costs associated with the installation of Consumers' Interconnection Facilities as identified in Subsection 1.3 and 1.4.

2.3 **Parallel Operation of the Project With Consumers' Distribution System**

Parallel operation of the Project with Consumers' distribution system shall only begin after the following conditions have been satisfied and confirmed in writing by Consumers to Project Developer:

2.3.1 Project Developer has met all of the requirements of Subsection 2.2;

2.3.2 Project Developer has obtained written approval by Consumers of all protective relay equipment required pursuant to Exhibit 1 – Scope of Facilities, Subsection 1.2 and the direct transfer trip equipment required pursuant to Subsections 1.2 and 1.3 for the protection of Consumers' distribution system. Approval will be granted after the required protective relay equipment is inspected and calibrated in accordance with the relay setting data issued by Consumers. Inspection and calibration must be either performed or witnessed by Consumers' personnel at Project Developer's expense. Project Developer must record the actual settings and inspection data on the relay-setting document furnished by Consumers and return such document to Consumers for approval;

2.3.3 Project Developer has developed operating and maintenance procedures, which Consumers has accepted in writing, for those protective devices which directly connect to Consumers' distribution system or interface with Consumers' protective devices;

2.3.4 Consumers has tested and accepted the telemetry / SCADA interface and concurs they meet the technical requirements as identified in the Telemetry and Disturbance Monitoring Requirements Section and the Communication Circuits Section of the Michigan Electric Utility Generator Interconnection Requirements. Testing must be performed by Consumers' personnel at Project Developer's expense and acceptance will be communicated to Project Developer in writing; and

2.3.5 Project Developer has developed operating procedures to manually trip generation for system security pursuant to Subsection 6.4, System Security.

2.4 **Subcontractors**

Either Party may hire a subcontractor to perform its obligations under this Agreement and shall incorporate the obligations of this Agreement into its respective subcontracts, agreements and purchase orders. Each Party shall remain liable to the other Party for the performance of such subcontractor under this Agreement and shall fully defend, indemnify and hold the other Party harmless from all acts or omissions of its subcontractors.

SECTION 3
OPERATION AND MAINTENANCE

3.1 **Operation and Maintenance By Consumers**

Consumers shall have sole authority and responsibility to operate and maintain Consumers' Interconnection Facilities required pursuant to Subsection 1.3, and in accordance with the applicable good utility practice standards of Consumers. Consumers may manually operate, when necessary, Consumers' Interconnection Facilities and the isolation device provided by Project Developer pursuant to Exhibit 1 – Scope of Facilities, Subsection 1.2, and may perform preventive or emergency maintenance, or make system modifications, when necessary, on Consumers' Interconnection Facilities. Normal maintenance shall be scheduled on Consumers' Interconnection Facilities taking into consideration Project Developer's schedule of maintenance for the Project. Such authority and responsibility shall include removing the Interconnection Facilities from service, when necessary, as determined by Consumers. Consumers shall not be required to deliver energy to the Project or provide a temporary connection to the Project when maintenance or system modifications require disconnecting Consumers' Interconnection Facilities from Consumers' distribution system.

3.1.1 Project Developer shall reimburse Consumers for all direct and indirect costs and expenses (including but not limited to, overtime pay, property taxes, insurance, equipment testing and inspections) incurred by Consumers in owning, operating and maintaining Consumers' Interconnection Facilities from the point in time in which Consumers' Interconnection Facilities are ready for service. Such costs and expenses shall be determined by Consumers in accordance with the standard practices and policies followed by Consumers and in effect at the time such operation and maintenance is performed. As used in this Agreement, the term "maintenance" includes inspection, repair and replacement. Payment by Project Developer of such costs and expenses shall be made in accordance with Subsection 3.1.4. In the event that Consumers uses any part of Consumers' Interconnection Facilities defined in Subsection 1.3 for the benefit of Consumers' customers, then the allocation of the ongoing costs and expenses which are due to the ownership, operation and maintenance of Consumers' Interconnection Facilities provided pursuant to Subsection 1.3, shall be re-determined with consideration for possible changes in: (a) Point of Delivery, (b) metering location, (c) operation and maintenance costs to Project Developer to new Point of Delivery, if any, and (d) compensation to Consumers for appropriate operating and maintenance costs from the new Point of Delivery, if any. Consumers shall not be restricted in the use of Consumers' Interconnection Facilities while such redetermination is being made.

- 3.1.2 If Consumers performs the following tasks on the Project Developer's behalf, the Project Developer shall reimburse Consumers for costs associated with (a) testing of metering and associated telemetry required pursuant to Subsection 2.2.4, (b) the relay setting information, inspection and calibration required pursuant to Subsection 2.3.2 and (c) the testing of the dispatching interface required pursuant to Subsection 2.3.4, which shall be separately billed by.
- 3.1.3 Project Developer shall be solely responsible for ordering, acquiring and all continuing operating expenses associated with the telephone circuits pursuant Exhibit 1 – Scope of Facilities, Subsection 1.2 as well as the proper safety equipment required for the proper installation of said telephone circuits. Additional operation and maintenance expenses associated with telemetry facilities are the responsibility of the Project Developer pursuant to Subsection 5.4.
- 3.1.4 Payments by Project Developer of the costs and expenses described in Subsections 3.1.1 and 3.1.2 are as follows:
- 3.1.4.1 As soon as practicable after the end of each month in which operation and maintenance costs and expenses were incurred by Consumers pursuant to Subsection 3.1.1 and 3.1.2, Consumers shall furnish Project Developer a statement describing the work performed or expense incurred and showing the amount of the payment to be made therefore by Project Developer.
- 3.1.4.2 Each statement shall be paid by Project Developer so that Consumers will receive the funds by the 20th day following the date of such statement, or the first business day thereafter if the payment date falls on a non-business day.
- 3.1.4.3 All payments shall be made payable to _____ and shall be sent to Consumers, Attention: _____, or by wire transfer to a Consumers' bank account or such other manner or at such place as Consumers shall, from time to time, designate by written notice to Project Developer. Payments made by wire transfer shall reference the appropriate invoice number for which payment is being made.
- 3.1.4.4 Any payment not made on or before the due date shall bear interest, from the date due until the date upon which payment is made, at an annual percentage rate of interest equal to the lesser of (a) the prime rate published by the Wall Street Journal (which represents the base rate on corporate loans posted by at least 75% of the nation's banks) on the date due, plus 2%, or (b) the highest rate permitted by law.

3.2 **Operation and Maintenance By Project Developer**

Except as provided in Subsections 2.3.2 and 3.1 and the provisions of this Subsection 3.2, Project Developer shall have sole authority and responsibility to operate and maintain the Project Developer's Interconnection Facilities required pursuant to Subsection 1.2 in accordance with prudent industry practices.

Relay settings, for protective devices required by Consumers, may be revised and documents stating such revisions may be issued by Consumers if it determines that it is necessary to do so. The settings for these devices may be revised only if Consumers issues documents specifying such revisions. In such event, the protective relay equipment shall be recalibrated by Project Developer in accordance with such revised relay settings within a reasonable period specified by Consumers. The procedure for recalibration and approval shall be the same as stated for the initial calibration pursuant to Subsection 2.3.2.

The protective relay equipment shall be tested every two (2) years (unless an extension is agreed to by Consumers) to verify the calibration indicated on the latest relay setting document issued by Consumers. If the protective relay equipment is not calibrated in accordance with the latest relay-setting document, it shall be recalibrated in accordance with Subsection 2.3.2, to conform with such data. Tests shall be conducted or witnessed by Consumers at Project Developer's expense. The results of such tests shall be provided to Consumers in writing for review and approval.

Consumers may, at any time in addition to that specified in the preceding paragraph, at Consumers' expense, inspect and test Project Developer's Interconnection Facilities to verify that the required protective interconnection equipment is in service, properly maintained, and calibrated to provide the intended protection. If necessary, this inspection may also include a review of Project Developer's pertinent records.

Inspection, testing and/or approval by Consumers or the omission of any inspection, testing and/or approval by Consumers pursuant to this Agreement shall not relieve Project Developer of any obligations or responsibility assumed under this Agreement.

SECTION 4 **ACCESS**

Consumers, its agents and employees, shall have full right and authority of ingress and egress at all reasonable times on and across the premises of Project Developer for the purpose of installing, operating, maintaining, inspecting, replacing, repairing, and removing its Interconnection Facilities located on the premises. The right of ingress and egress, however, shall not unreasonably interfere with Project Developer's use of its premises.

SECTION 5 **INTERCONNECTION POINT; POINT OF DELIVERY; METERING; TELEMETERING**

5.1 Interconnection Point

The Interconnection Point shall be where the Project Developer's Interconnection Facilities connect to Consumers' distribution system.

5.2 Point of Delivery

If the Project is connected to a distribution line serving other customers, the Point of Delivery shall be at the high voltage side of the Project supplied isolation transformer connecting the Project to Consumers' distribution system. Otherwise, the Point of Delivery shall be the point at which the radial line connecting the Project to Consumers' distribution system terminates at the first substation beyond the Project's isolation transformer.

5.3 Metering

Measurements of electric energy deliveries shall be made by standard types of electric meters installed and maintained by Consumers pursuant to Exhibit 1 – Scope of Facilities, Subsection 1.3.

The standard electric meters shall be tested by Consumers at least once every six (6) years. On request and at the expense of the Project Developer, a special test may be performed. Representatives of Project Developer shall be afforded the opportunity to be present at all routine or special tests and upon occasions when any readings, for purposes of settlements, are taken from meters not bearing an automatic record.

5.4 Telemetry

Certain telemetry facilities will be provided by Consumers pursuant to Exhibit 1 – Scope of Facilities, Subsection 1.3 as a part of the Interconnection Facilities as being necessary for the proper and efficient collection of metering and control data. The cost and maintenance of such telemetry facilities and associated phone lines shall be borne by Project Developer.

SECTION 6 **SERVICE CONDITIONS**

6.1 Site Preparation

At its own expense, the Project Developer shall make the proposed Project site available to Consumers. Said site shall be free from hazard and shall be adequate for the operation and construction of distribution facilities necessary to interconnect the proposed Project.

6.2 Parallel Operation

It is understood that the Project will normally remain connected to and be operated in parallel with Consumers' distribution system. The Project Developer shall, at its expense, install and properly maintain protective equipment and devices and provide sufficiently trained personnel to protect its equipment and service, and the equipment and service of Consumers from damage, injury or interruptions during the Project's parallel operation with Consumers' distribution system, and, without limiting the indemnity provided in Subsection 7.1 herein, Project Developer shall assume any loss, liability or damage to Project Developer and Consumers' distribution system and equipment caused by lack of or failure of such protection. Such protective equipment specifications and design shall be consistent with the Michigan Electric Utility Industry Generator Interconnection Requirements, and any successor and/or supplemental documents. Prior to the Project operating in parallel with Consumers' distribution system, the Project Developer shall provide satisfactory evidence to Consumers that it has met the Michigan Electric Utility Generator Interconnection Requirements that are on file with the Michigan Public Service Commission and complied with all applicable laws, rules, regulations, guidelines, and safety standards.

6.3 **Voltage Control**

Project Developer shall cooperate with Consumers to regulate the voltage level at the Point of Delivery by controlling its generators in accordance with Consumers' instructions. Such instructions shall include, but not be limited to, (a) maintaining voltage or (b) delivering real and reactive power to the Point of Delivery at levels specified by Consumers. The instructions given by Consumers shall be consistent with the normal practices adhered to by Consumers with respect to its own generators located on its system.

6.4 **System Security**

Installation, inspection, and calibration of relaying to trip generation for under- or over-frequency operation shall be coordinated with Consumers, pursuant to Subsection 2.3.2, so as not to degrade the security of Consumers' distribution system. Operating practices developed by Project Developer which call for manual tripping of generation for under-or over-frequency operation shall likewise be coordinated and be consistent with the provisions of East Central Area Reliability Document 3, "Emergency Procedures" During Declining System Frequency, and any successor and/or supplemental documents, which are incorporated herein by reference.

6.5 **Continuity of Service**

Each Party shall exercise reasonable care to maintain continuity of service in the delivery and receipt of electric energy. If service becomes interrupted for any reason, the cause of such interruption shall be removed and normal operating conditions restored as soon as practicable.

6.6 **Project Backup Power**

If the Project Developer requires backup power from Consumers, the Project Developer will contract with Consumers for the delivery of power provided to the Project under one of Consumers' established retail rates set forth in Consumers' tariffs, which are incorporated herein by reference. The provisions of such contract shall be applied during periods when the Project is not delivering energy to Consumers. The Project Developer will contract with Consumers for the purchase of energy or provide satisfactory evidence of the purchase of energy from an alternative energy supplier for the purpose of providing power to the Project during periods when the Project is not delivering energy to Consumers' distribution system.

Project Developer shall have sufficient voltage regulation at the Project to maintain an acceptable voltage level for Project equipment during such periods when the Project's generation is off line.

6.7 **Consumers' Obligation to Connect**

Consumers shall not be obligated to continue the electrical interconnection to the Project if it determines, in its sole discretion, that any one or more of the following conditions exist, including but not limited to: (a) those conditions listed in the Miscellaneous Operational Requirements section of the Michigan Electric Utility Generator Interconnection Requirements, (b) electrical characteristics of the Project are not compatible with the electrical characteristics of Consumers' distribution system, (c) the Project Developer is deficient in following either the voltage schedule or reactive power schedule established by Consumers, (d) an emergency condition exists on Consumers' distribution system, (e) Project Developer's protective relay equipment fails, resulting in a lack of the level of protection required by prudent utility practice, (f) the Project Developer's Project is determined to be disrupting Consumers customers, (g) Consumers requires disconnection of the Project in order to construct, install, maintain, repair, replace, remove, investigate, inspect or test any part of Consumers' Interconnection Facilities or any other Consumers equipment associated with the interconnection (also if a required component (example: phone line) or required modification to allow interconnection fails or becomes incapacitated and is not repaired in a timely manner), (h) by mutual consent, (i) Project Developer commits a material breach of this agreement or (j) Project Developer's failure to execute this agreement or upon cancellation or termination of this agreement. Consumers shall electrically connect or reconnect its distribution system to the Project when, in Consumers' sole opinion, the conditions named above cease to exist. Under any of the conditions listed above, Consumers will follow the procedures for disconnecting and re-connecting the interconnection as outlined in Appendix F of the appropriate Michigan Electric Utility Generator Interconnection Requirements document.

SECTION 7
INDEMNITY; INSURANCE

7.1 Indemnity

To the extent permitted by law, Project Developer covenants and agrees that it shall hold the Consumers, and all of its agents, employees, officers and affiliates harmless for any claim, loss, damage, cost, charge, expense, lien, settlement or judgment, including interest thereon, whether to any person or property or both, arising directly or indirectly out of, or in connection with this Agreement, the Project, or any of Project Developer's facilities and associated appurtenances, to which the Consumers or any of its agents, employees, officers or affiliates may be subject or put by reason of any act, action, neglect or omission on the part of the Consumers or the Project Developer or any of its contractors or subcontractors or any of their respective officers, agents, employees, and affiliates (excluding claims based on the Consumers' reckless or intentional misconduct). If this Agreement is one subject to the provisions of Michigan Act No. 165, PA 1966, as amended, then Project Developer will not be liable under this section for damages arising out of injury or damage to persons or property directly caused or resulting from the sole negligence of the Consumers, or any of its officers, agents or employees. The provisions of this Subsection 7.1 shall survive termination or expiration of this Agreement.

7.2 Insurance

Project Developer shall obtain and continuously maintain throughout the term of this Agreement General Liability insurance written on a standard occurrence form, or other form acceptable to Consumers, and covering bodily injury and property damage liability with a per occurrence and annual policy aggregate amount of at least:

Minimum Limit
\$1,000,000

When requested in writing by Consumers, said limit shall be increased each year that this Agreement is in force to a limit no greater than the amount arrived at by increasing the original limit by the same percentage change as the Consumer Price Index - All Urban Workers (CPI-U.S. Cities Average). Such policy shall include, but not be limited to, contractual liability for indemnification assumed by Project Developer under this Agreement.

Consumers shall be named as an additional insured under such policy. The policy shall be primary coverage with no contribution from any insurance maintained by Consumers. Consumers shall not be responsible for any unpaid premiums under Project Developer policy.

Evidence of insurance coverage on a certificate of insurance shall be provided to Consumers upon execution of this Agreement and thereafter within ten (10) days after expiration of coverage; however, if evidence of insurance is not received by the 11th day, Consumers has the right, but not the duty, to purchase the insurance coverage required under this Section and to charge the annual premium to Project Developer. Consumers shall receive thirty (30) days advance written notice if the policy is cancelled or substantial changes are made that affect the additional insured. At Consumers' request, Project Developer shall provide a copy of the policy to Consumers. All certificates and notices shall be mailed to:

SECTION 8
LIMITATION ON LIABILITY

Neither party shall in any event be liable to the other for any incidental or consequential damages such as, but not limited to, lost profits, revenue or good will, interest, loss by reason of shutdown or non-operation of equipment or machinery, increased expense of operation of equipment or machinery, cost of purchased or replacement power or services or claims by customers, whether such loss is based on contract, warranty, negligence, strict liability or otherwise. Even if it has been advised of the possibility of such damages.

SECTION 9
FORCE MAJEURE

Neither Party shall be liable for failure to perform any of its obligations hereunder, to the extent due to fire, flood, storm, other natural disaster, national emergency or war (referred to collectively as "Force Majeure"), and not due to labor problems, inability to obtain financing, negligence or other similar condition of such party, provided that

either party has given the other prompt notice of such occurrence. The Party affected shall exercise due diligence to remove such Force Majeure with reasonable dispatch, but shall not be required to accede or agree to any provision not satisfactory to it in order to settle and terminate a strike or other labor disturbance.

SECTION 10 **DEFAULT**

A default of this Agreement ("Default") shall occur upon the failure of a Party to perform or observe any material term or condition of this Agreement, which includes, but is not limited to:

- a. Failure to pay money when due;
- b. Failure to comply with any material term or condition of this Agreement, including but not limited to any breach of any material representation, warranty or covenant made in this Agreement;
- c. A Party: (i) becomes insolvent; (ii) files a voluntary petition in bankruptcy under any provision of any federal or state bankruptcy law or shall consent to the filing of any bankruptcy or reorganization petition against it under any similar law; (iii) makes a general assignment for the benefit of its creditors or (iv) consents to the appointment of a receiver, trustee or liquidator;
- d. Assignment of this Agreement in a manner inconsistent with the terms of this Agreement;
- e. Failure of either Party to provide information or data to the other Party as required under this Agreement, provided the Party entitled to the information or data under this Agreement requires such information or data to satisfy its obligations under this Agreement.

In the event of a Default by either Party, the Parties shall continue to operate and maintain, as applicable, its Interconnection Facilities, protection and Metering Equipment, transformers, communication equipment, building facilities, software, documentation, structural components and other facilities and appurtenances that are reasonably necessary for Consumers to operate and maintain Consumers' distribution system and for the Project Developer to operate and maintain its Project in a safe and reliable manner. Upon a Default, the non-defaulting Party shall give written notice of such Default to the defaulting Party. The defaulting Party then has 30 days to cure the Default. If a Default is not cured within the period provided for herein or as agreed to by the Parties, the non-defaulting Party shall have the right to terminate this Agreement and, recover any damages, and/or pursue any other remedies available under this Agreement, by law, or in equity. Termination is not the non-defaulting Party's exclusive remedy and is in addition to any other rights and remedies it may have under this Agreement or by law. Failure of non-defaulting Party to exercise any of its rights under this Section shall not excuse defaulting Party from compliance with the provisions of this Agreement nor prejudice rights of Company to recover damages for such default.

SECTION 11 **SUCCESSORS AND ASSIGNS**

This Agreement shall inure to the benefit of and be binding upon the successors and assigns of the respective Parties hereto. This Agreement shall not be assigned, transferred or otherwise alienated without the other Party's prior written consent, which consent shall not unreasonably be withheld. Any attempted assignment, transfer or alienation without such written consent shall be void.

SECTION 12 **GOVERNING LAW**

This Agreement shall be deemed to be a Michigan contract and shall be construed in accordance with and governed by the laws of Michigan, exclusive of its conflict of laws principles.

SECTION 13 **EFFECTIVE DATE, TERM AND TERMINATION**

The Effective Date of this Agreement shall be the date of execution and shall continue in effect until this Agreement is terminated as provided herein. The Agreement may be terminated at any time by mutual agreement of both Parties, or by either Party upon giving the other at least ninety (90) days written notice if one or more of the conditions exist as outlined in Subsection 6.7, Consumers' Obligation to Connect.

SECTION 14
RETIREMENT

Upon termination of this Agreement pursuant to Section 13 or at such time after any of the Interconnection Facilities described herein are no longer required, the Parties shall mutually upon the retirement of said Interconnection Facilities which may include without limitation (i) dismantling, demolition, and removal of equipment, facilities, and structures, (ii) security, (iii) maintenance and (iv) disposing of debris. The cost of such removal shall be borne by the Party owning such Interconnection Facilities.

SECTION 15
ENTIRE AGREEMENT AND AMENDMENTS

This Agreement and the Michigan Electric Utility Generator Interconnection Requirements shall constitute the entire understanding between the Parties with respect to the subject matter hereof, supersedes any and all previous understandings between the Parties with respect to the subject matter hereof, and bind and insure to the benefit of the Parties, their successors, and permitted assigns. No amendments or changes to this Agreement shall be binding unless made in writing and duly executed by both Parties.

SECTION 16
NO PARTNERSHIP

This Agreement shall not be interpreted or construed to create an association, joint venture, agency relationship, or partnership between the Parties or to impose any partnership obligation or partnership liability upon either Party. Neither Party shall have any right, power or authority to enter into any agreement or undertaking for, or act on behalf of, or to act as or be an agent or representative of, or to otherwise bind, the other Party.

SECTION 17
SEVERABILITY

If any provision or portion of this Agreement shall for any reason be held or adjudged to be invalid or illegal or unenforceable by any court of competent jurisdiction or other Governmental Authority, (i) such portion or provision shall be deemed separate and independent, (ii) the Parties shall negotiate in good faith to restore insofar as practicable the benefits to each Party that were affected by such ruling, and (iii) the remainder of this Agreement shall remain in full force and effect.

SECTION 18
NOTICE TO PARTIES

Unless otherwise provided in this Agreement, any notice, consent or other communication required to be made under this Agreement, shall be in writing and (i) mailed postage prepaid, by certified or registered mail, return receipt requested; (ii) mailed via a nationally recognized overnight delivery service, or (iii) delivered in person to the address as the receiving Party may designate in writing.

All notices shall be effective when received.

SECTION 19
NO THIRD PARTY BENEFICIARIES

This Agreement is intended for the benefit of the Parties hereto and does not grant any rights to any third parties unless otherwise specifically stated herein.

**SECTION 20
SECTION HEADINGS**

The various headings set forth in this Agreement are for convenience of reference only and shall in no way affect the construction or interpretation of this Agreement.

IN WITNESS WHEREOF, the Parties hereto have executed this Agreement.

CONSUMERS ENERGY COMPANY

Customer Name

By: _____
(Signature)

By: _____
(Signature)

(Print or Type Name)

(Print or Type Name)

Title: _____

Title: _____

Date: _____

Date: _____

(Project Developer Name)

By: _____
(Signature)

(Print or Type Name)

Title: _____

Date: _____

Review and Approval		
Reviewer	Signature	Date

EXHIBIT 1
SCOPE OF FACILITIES

1.1 General Facilities

Such facilities and associated appurtenances as required to interconnect Consumers' existing ____ - ____ distribution line to the Project Developer's [new / modified](#) ____ MW Project by way of a new or modified interconnection, which shall include, but shall not be limited to the following:

1.2 Project Developer's Interconnection Facilities

(Insert file containing Project Developer's Interconnection Facilities below)

1.3 Consumers' Interconnection Facilities

(Insert file containing Consumers' Interconnection Facilities below)

EXHIBIT 2
WIRING DIAGRAM

(Insert file containing Wiring Diagram below)

APPENDIX G
CONTACT LIST

CONTACT LIST

Normal Operations and Emergency Switching
[Project Name]

GENERAL

Switching and clearance procedures for Consumers Energy Company ("Consumers") and the Customer provide important documentation to ensure safe working conditions and orderly and reliable service when work is required on the Interconnection Facilities.

PROCEDURE

1. Emergency Switching Procedure:

Operating Authority for the Customer will be handled by the following "Priority Contact List."

- | | | |
|---------------------------------|-------------------|----------------|
| a. Customer's Plant | [Work/Cell/Pager] | [phone number] |
| b. Project Operator | [Work/Cell/Pager] | [phone number] |
| c. 1 st Contact Name | [Work/Cell/Pager] | [phone number] |
| d. Second Contact | if applicable | |
| e. Third Contact | if applicable | |

Operating Authority for Consumers will be the System Controller located in [Jackson or Grand Rapids], Michigan. Telephone number is [phone number].

2. Scheduled Outage Procedure:

Request initiated by the Customer.

Operating Authority for the Customer will be [Contact Name], Project Operator or an authorized representative. [Contact Name] or an authorized representative will contact the System Control Scheduler to make the necessary arrangements and to agree on the switching procedures.

Request initiated by Consumers.

Scheduling Authority for Consumers will be the System Control Scheduler located in [Jackson or Grand Rapids], Michigan. Contact number is [phone number].

The System Control Scheduler will contact [Contact Name] or an authorized representative to make necessary arrangements and to agree on switching procedures.

NOTE: Each authority will attempt to provide a minimum of 72 hours notice on scheduled outage requests, except in an emergency or imminent equipment failure.

IN WITNESS WHEREOF, the Parties hereto have executed this Agreement as of the Effective Date identified below.

CUSTOMER NAME

CONSUMERS ENERGY COMPANY

By _____

By _____

Title _____

Title _____

Effective Date _____